

POLICY NAME

Kingswood Public Domain Manual

DATE ADOPTED

29 September 2014

ECM NUMBER

6319636

REVIEW DATE

June 2020

POLICY NUMBER

PM 001

COUNCIL MINUTE NUMBER

ORD 276

POLICY TYPE

Council

RESPONSIBLE DEPARTMENT

Place Management

RELATED DOCUMENTS

Users of this document should also refer to the following documents for guidance:

- Penrith Local Environment Plan 2010
- Penrith Development Control Plan 2010
- Penrith Urban Study and Strategy
- All references to Australian Standards are to be to current published standards
- Disability Discrimination Act and DDA standards for Public Transport
- Penrith Local Inclusion Plan - People with Disabilities 2009-2013
- Penrith City Council Standard Details for Kerbs and Gutters, Footpaths and Kerb Ramps

Purpose

While the LEP and DCP guide developments on private property this document will guide improvements required to the public domain. The purpose of this is to ensure that improvements are done in a consistent manner with adherence to a specific urban design theme and distinctive character.

Policy Statement

In summary this document aims to:

- Clearly define new design standards for the Kingswood public domain.
- Create a consistent streetscape treatment to define the character of Kingswood.
- Implement Councils sustainability principles and relevant policies in the design standards and use of materials.
- Ensure accessibility outcomes consistent with current legislation, codes, standards and Council policies.
- Standardise design and construction methods through standard drawings and specifications.

Scope

This policy applies to Council and the community.



PENRITH CITY COUNCIL

KINGSWOOD PUBLIC DOMAIN MANUAL

Adopted 29 September 2014



KINGSWOOD PUBLIC DOMAIN MANUAL

Client:
PENRITH
CITY COUNCIL

Prepared by



CLOUSTON associates
Landscape Architects • Urban Designers • Landscape Planners
Level 2, 17 Bridge Street • Sydney NSW 2000
PO Box R1388 • Royal Exchange NSW 1225 • Australia
Telephone +61 2 8272 4999 • Facsimile +61 2 8272 4998
Contact: Leonard Lynch
Email • sydney@clouston.com.au
Web • www.clouston.com.au

Document	Issue	Date	Status	Reviewed	Verified	Validated
S13-0035 R01	A	27/06/2013	DRAFT	NB		
S13-0035 R01	B	06/08/2013	DRAFT	NB	PA	
S13-0035 R01	C	20/09/2013	DRAFT	NB	NB	
S13-0035 R01	D	18/10/2013	FINAL	NB	NB	HM
S13-0035 R01	E	30/01/2013	FINAL	PB	NB	CL
S13-0035 R01	F	13/02/2013	FINAL	PB	NB	

Note: this document is Preliminary unless validated by a Principal of CLOUSTON Associates.

TABLE OF CONTENTS

Title	page
SITE PLAN	4
INTRODUCTION	5
STREET HIERARCHY	6
STREET AND LANDSCAPE CHARACTER	7
TYPICAL STREET SECTION - PRIMARY STREETS	8
TYPICAL STREET SECTION - SECONDARY STREETS	14
TYPICAL STREET SECTION - TERTIARY STREETS	16
TYPICAL STREET LAYOUT PLAN - RESIDENTIAL	20
TYPICAL STREET LAYOUT PLAN - COMMERCIAL	21
STREET TREE PLAN	22
STREET TREE SPECIES	23
STREET TREE PLANTING DETAILS	24
TYPICAL INTERSECTION 1	26
TYPICAL INTERSECTION 2	27
TYPICAL INTERSECTION 3	28
KERB RAMPS	29
PAVING MATERIALS	30
PAVING DETAILS - CONCRETE FOOTPATH	32
PAVING DETAILS - UNIT PAVING	34
TACTILE INDICATORS	38
SERVICE COVERS	39
STREET FURNITURE	40
LIGHTING PRINCIPLES	42
MAINTENANCE GUIDELINES	43
PROJECT CREDITS	44



SITE PLAN



INTRODUCTION

Background

Kingswood is developing as a major specialised centre in the Penrith local government area of Western Sydney. Kingswood is allied to the growth of the Penrith Health and Education Precinct which includes the Nepean Hospital, The University of Western Sydney and the Western Sydney Institute of TAFE. As well as the existing groups of shops along the Great Western Highway and Bringely Road several new large developments in the precinct are planned or approved. Many of these developments will require upgrades to the adjacent public domain.

In the absence of a specific public domain infrastructure policy, Council has commissioned this document as a guide for achieving best practice design techniques.

Purpose Of This Document

While the LEP and DCP guide developments on private property this document will guide improvements required to the public domain. The purpose of this is to ensure that improvements are done in a consistent manner with adherence to a specific urban design theme and distinctive character. In summary this document aims to:

- Clearly define new design standards for the Kingswood public domain.
- Create a consistent streetscape treatment to define the character of Kingswood.
- Implement Councils sustainability principles and relevant policies in the design standards and use of materials.
- Ensure accessibility outcomes consistent with current legislation, codes, standards and Council policies.
- Standardise design and construction methods through standard drawings and specifications.

Structure Of This Document

This document has been set out to allow developers and Council officers to understand the design and layout principles for any given street within the boundary specified on page 4. It is structured so that design principles can be applied at various scales from street hierarchy and overall dimensions through to design details, materials and furniture specifications.

How To Use This Manual

This manual is intended for use by developers, designers and Council officers when submitting and assessing a development application. For any given development the user of this manual should follow these simple steps in this order:

- Identify which street or streets the given development has a frontage.
- Identify the street character and typical dimensions illustrated in the relevant 'typical street section' of the manual.
- Identify other layout requirements such as street trees, driveways, lighting and kerb ramps.
- Refer to the relevant design details and materials and furniture guidance described in this manual.
- Ensure that development proposals comply with the provisions identified within this manual.
- Ensure that accessibility for people with disabilities is provided to all new works including future bus stops and accessible parking.

Related Documents

Users of this document should also refer to the following documents for guidance:

- Penrith Local Environment Plan 2010.
- Penrith Development Control Plan 2010.
- Penrith Urban Study and Strategy.
- All references to Australian Standards are to be to current published standards.
- Disability Discrimination Act and DDA standards for Public Transport.
- Penrith Local Inclusion Plan - People with Disabilities 2009-2013.
- Penrith City Council Standard Details for Kerbs and Gutters, Footpaths and Kerb Ramps

STREET HIERARCHY



STREET AND LANDSCAPE CHARACTER

HIERARCHY

The street hierarchy for the study area classifies streets as either Primary, Secondary or Tertiary streets depending on a combination of the following criteria:

- Likely volume of traffic.
- Wider traffic and pedestrian connections.
- Nature of landuse - residential, health, commercial.
- Likely volume of pedestrians (including cyclists).
- Strategic and future pedestrian connections.



PRIMARY

These are major urban streets that convey high volumes of vehicular traffic passing through the wider region. They have the potential to present and increase the profile of the Kingswood centre by ensuring high levels of presentation. Public domain elements will need to be highly robust, consistent and functional whilst utilising hard and soft landscape to provide a positive image for the area that sets it apart from surrounding centres. There should be generous areas for circulation, minimal clutter from urban elements and promote a more civic feel than secondary or tertiary streets.

SECONDARY

These streets distribute local traffic and pedestrians between shopping centres and key facilities such as the Nepean Hospital. They have the potential to provide on and off-road cycle links away from busy primary streets. The public domain will primarily need to respond to the functional needs of pedestrians and cyclists. The use of street tree planting in larger verge widths will distinguish them from tertiary streets.

TERTIARY

Tertiary streets are those that are subject to lower traffic volumes, providing local access to properties off primary and secondary streets. Their character should be 'scaled down', with narrower carriageways, verges and standard pedestrian path widths. Street tree planting will still be important reflecting the softer more intimate scale of the street.

TYPICAL STREET SECTION - PRIMARY STREET

TYPICAL STREET SECTION 1 - GREAT WESTERN HIGHWAY - EXISTING COMMERCIAL SETBACK

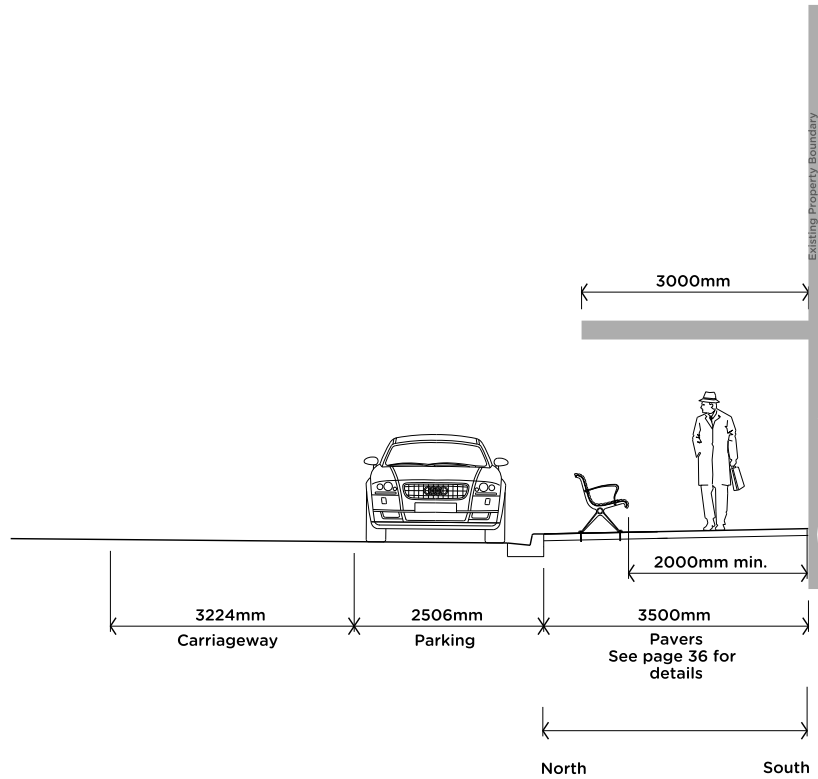

TYPICAL STREET SECTION - PRIMARY STREET

TYPICAL STREET SECTION 2 - GREAT WESTERN HIGHWAY - INCREASED COMMERCIAL SETBACK

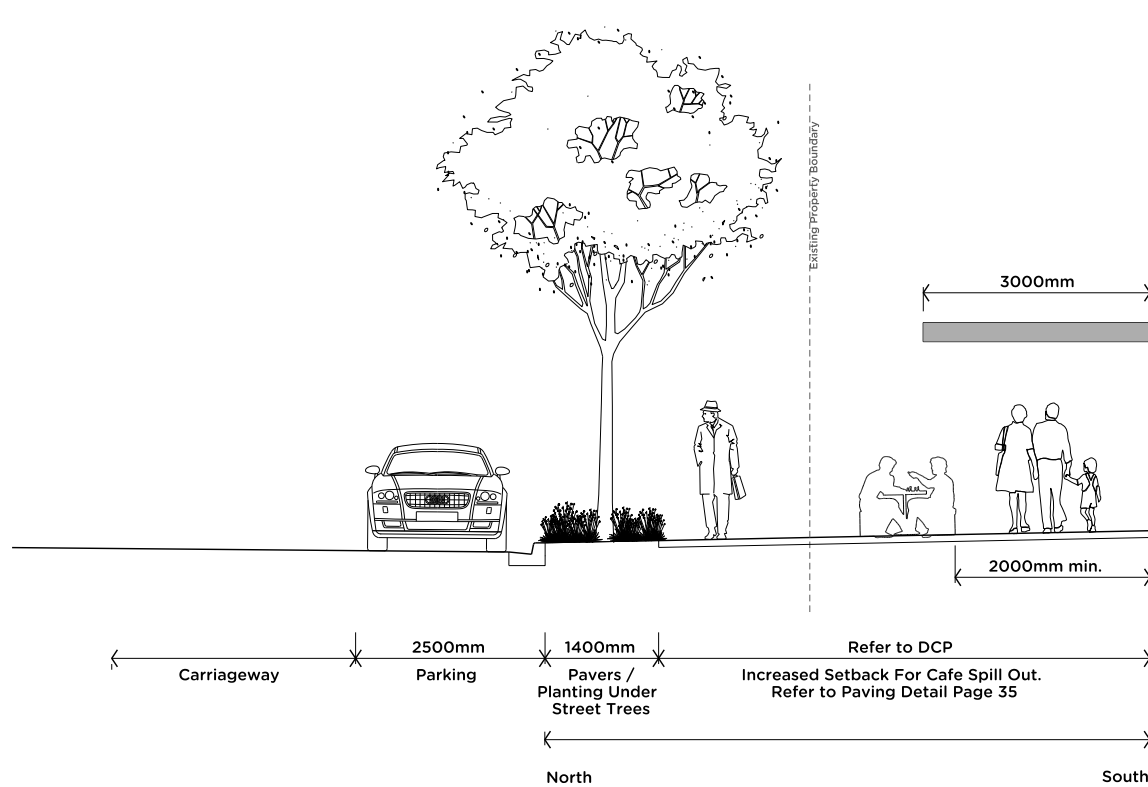

TYPICAL STREET SECTION - PRIMARY STREET

TYPICAL STREET SECTION 3 - GREAT WESTERN HIGHWAY - NEPEAN HOSPITAL BOUNDARY

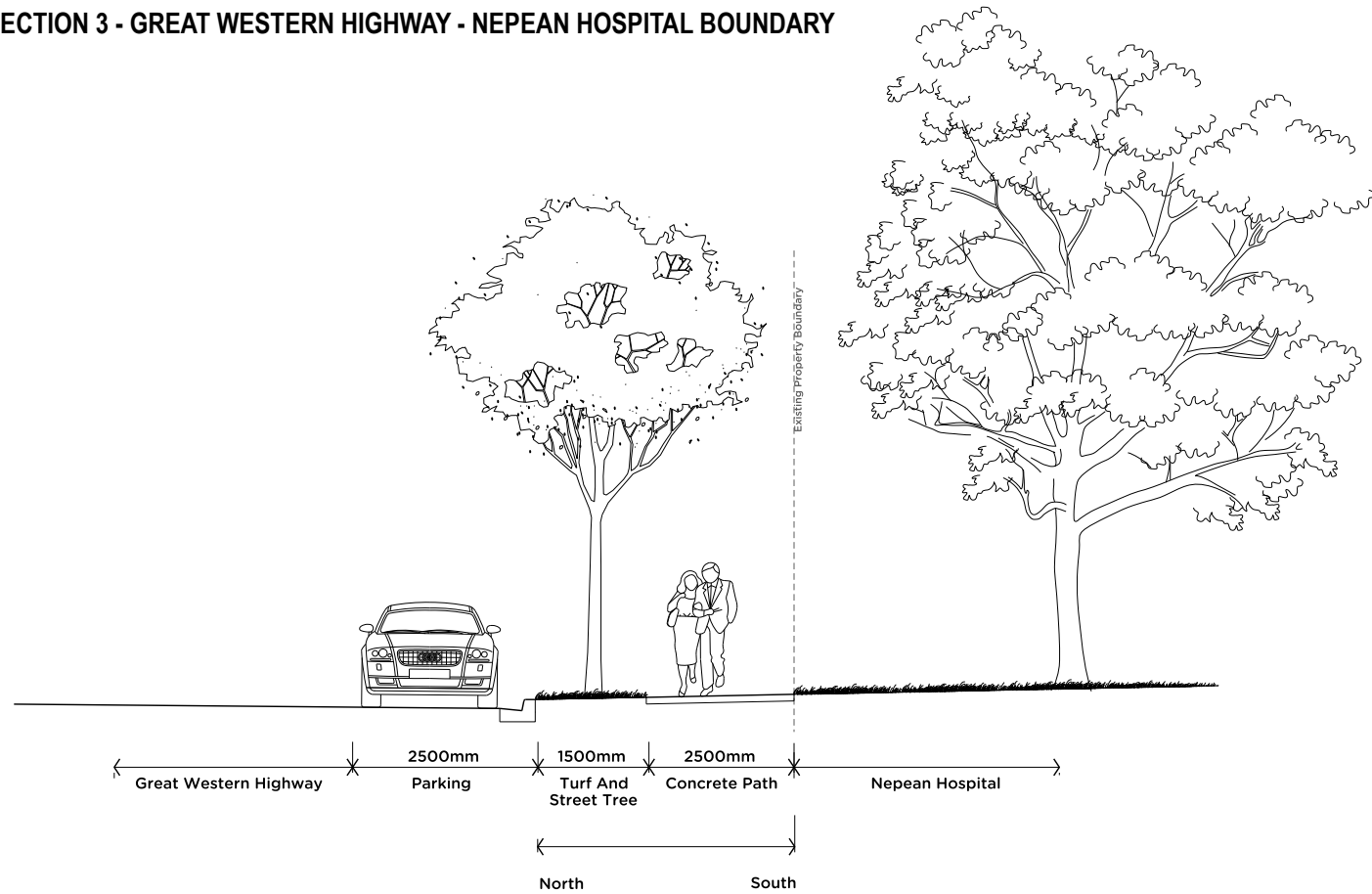

TYPICAL STREET SECTION - SECONDARY STREET

TYPICAL STREET SECTION 4 - THE NORTHERN ROAD

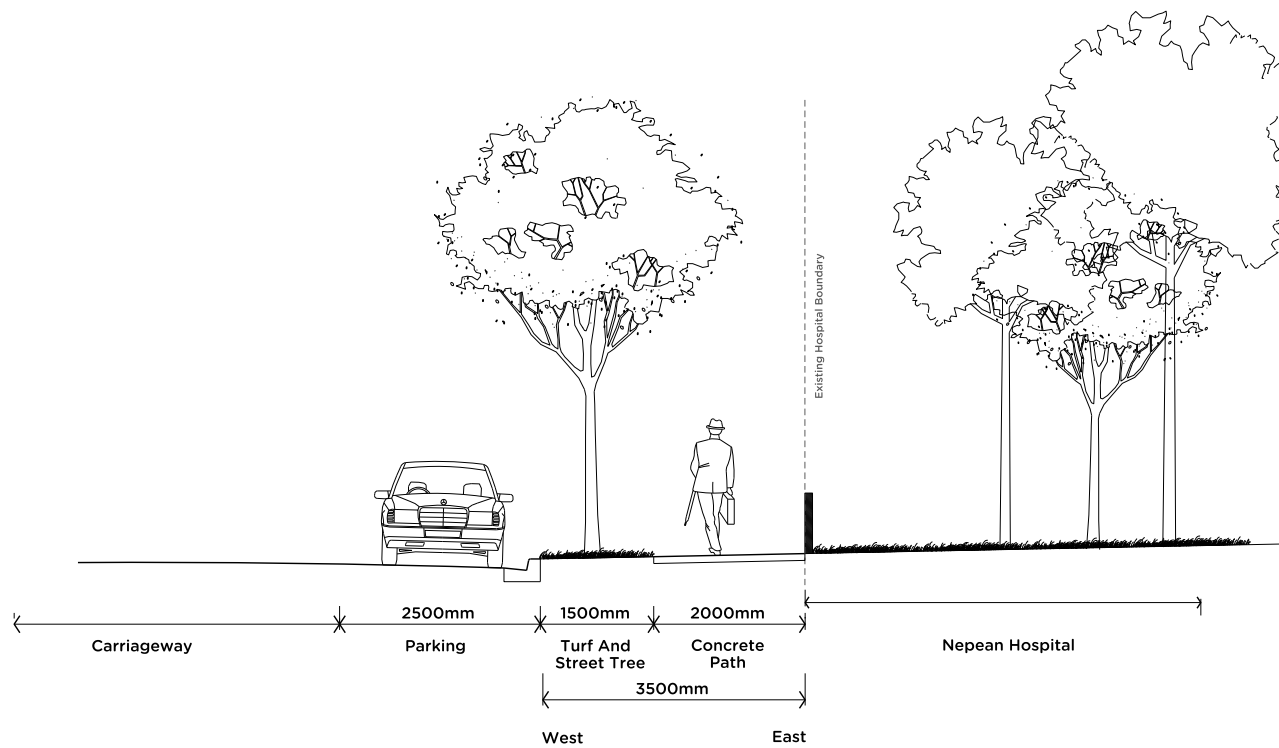

TYPICAL STREET SECTION - PRIMARY STREET

TYPICAL STREET SECTION 5 - BRINGELLY ROAD - COMMERCIAL FRONTAGE

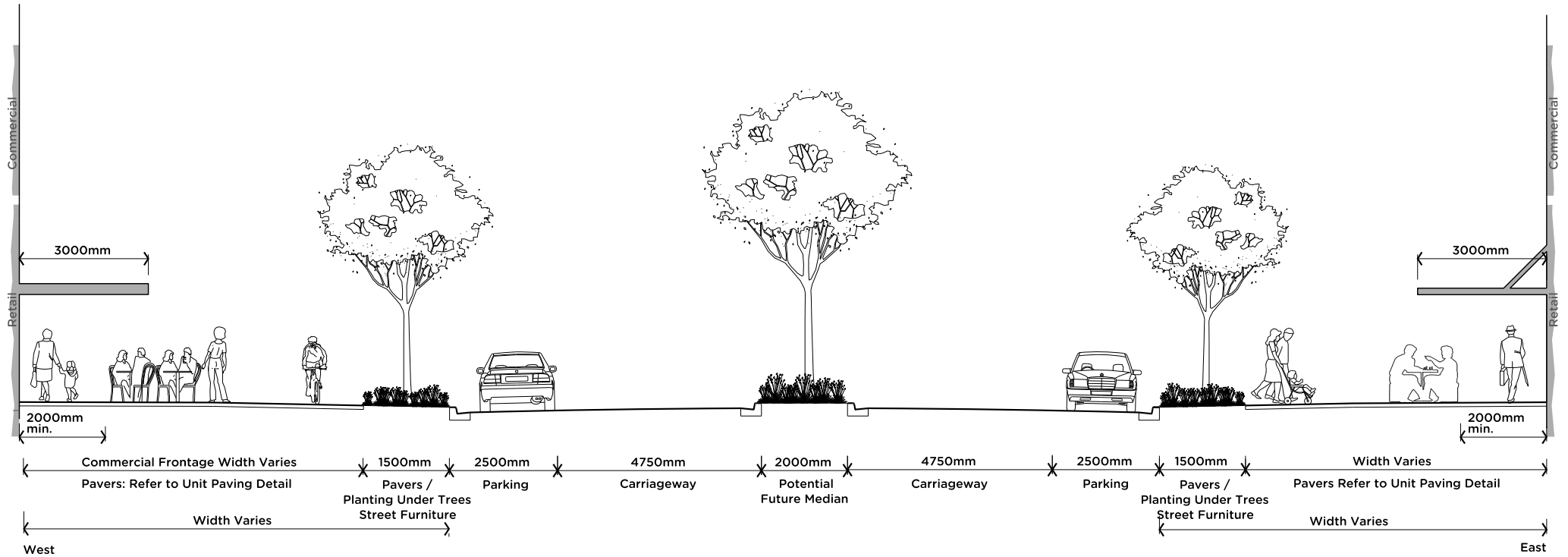

TYPICAL STREET SECTION - PRIMARY STREET

TYPICAL STREET SECTION 6 - BRINGELLY ROAD - RESIDENTIAL FRONTAGE

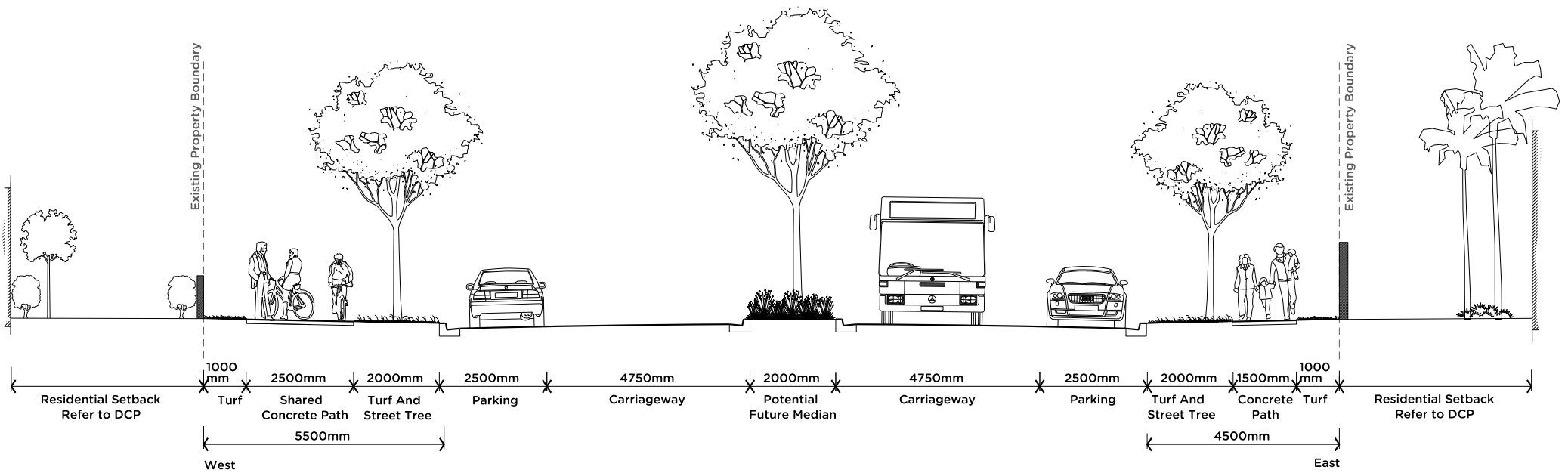

TYPICAL STREET SECTION - SECONDARY STREET

TYPICAL STREET SECTION 7 - SOMERSET STREET

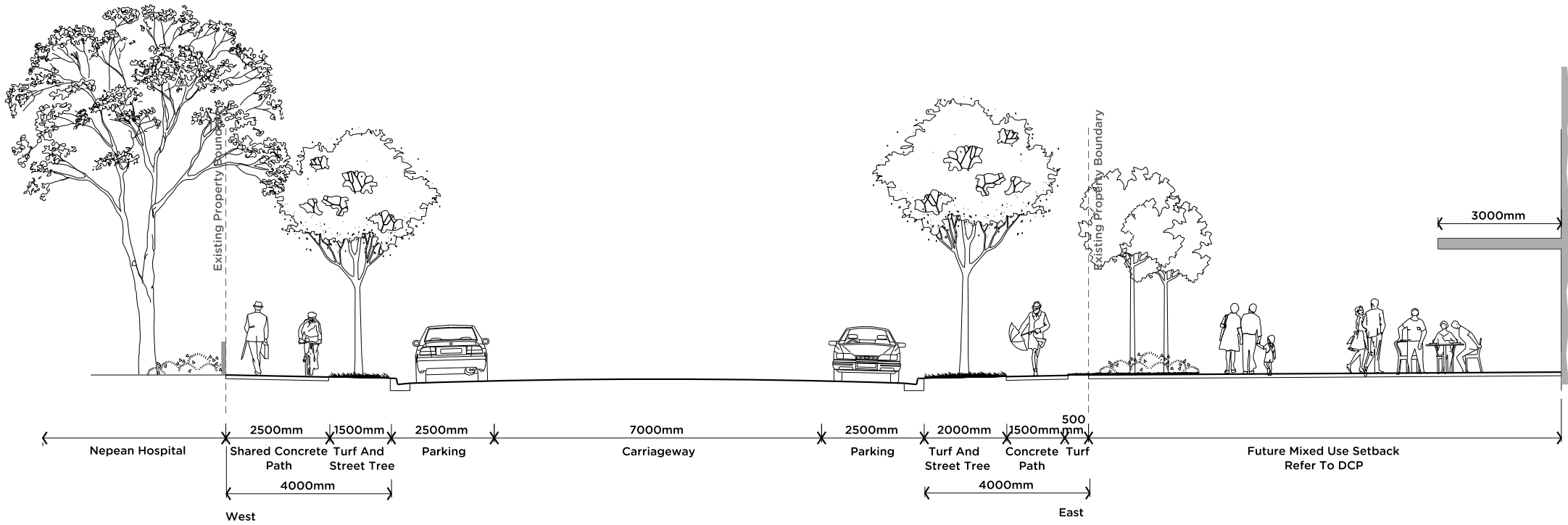

TYPICAL STREET SECTION - SECONDARY STREET

TYPICAL STREET SECTION 8 - DERBY STREET

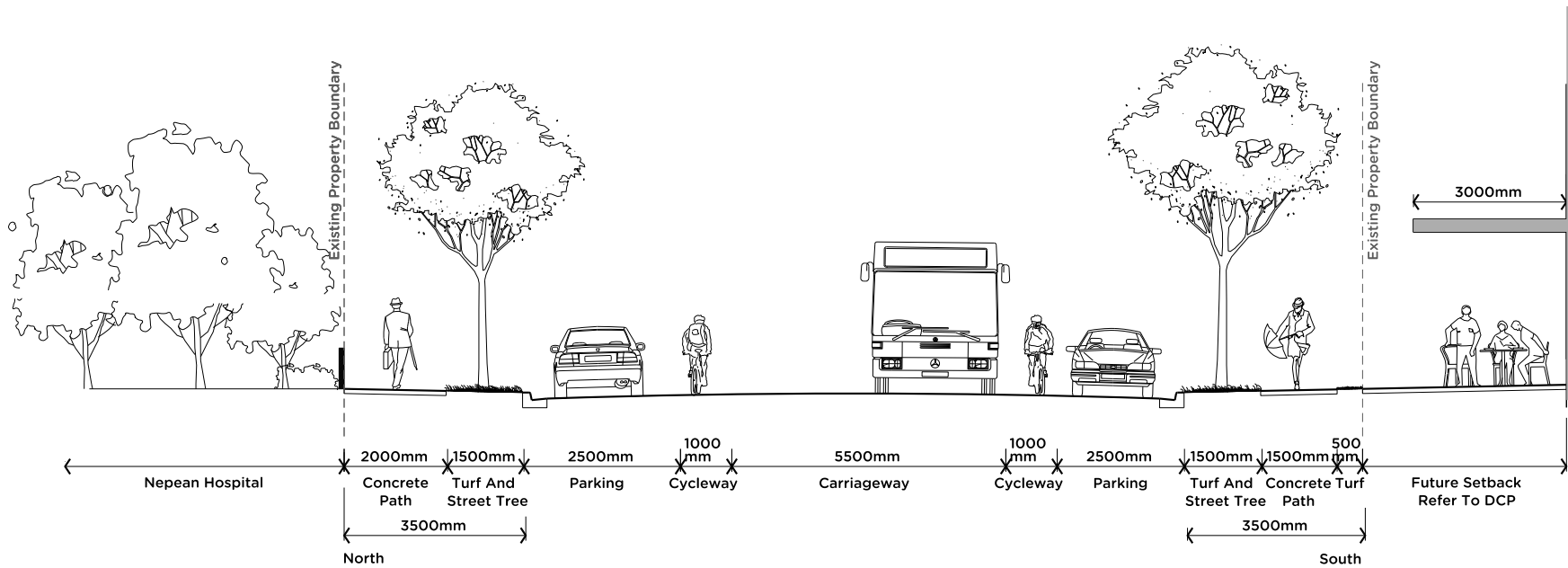

TYPICAL STREET SECTION - TERTIARY STREET

TYPICAL STREET SECTION 9 - ORTH STREET

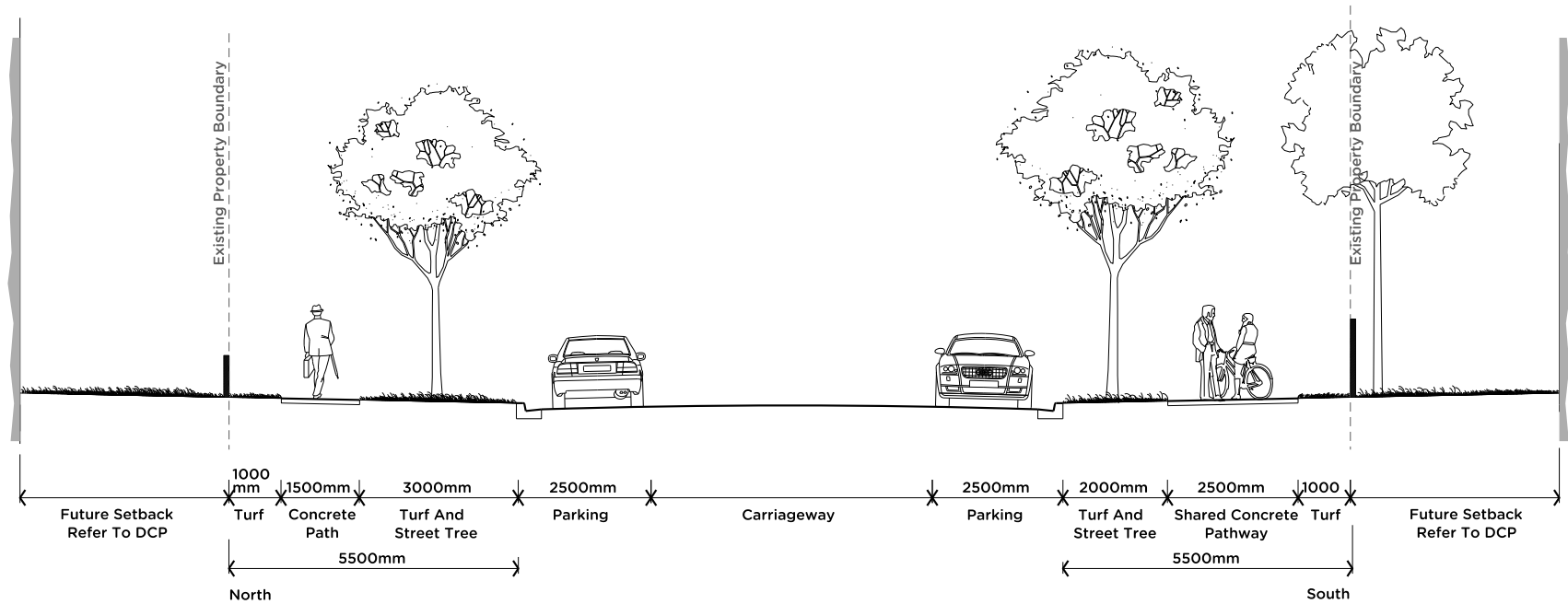

TYPICAL STREET SECTION - TERTIARY STREET

TYPICAL STREET SECTION 10 - WAINWRIGHT LANE

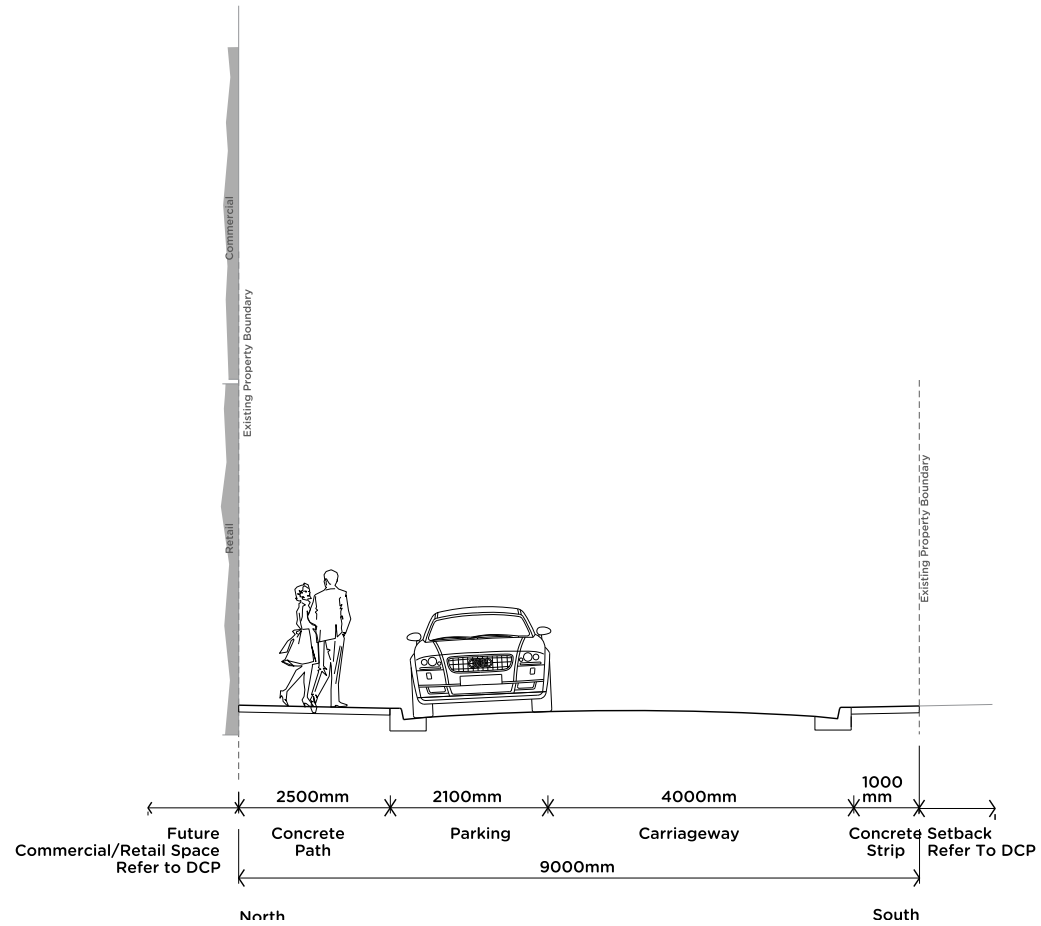

TYPICAL STREET SECTION - TERTIARY STREET

TYPICAL STREET SECTION 11 - RODGERS STREET

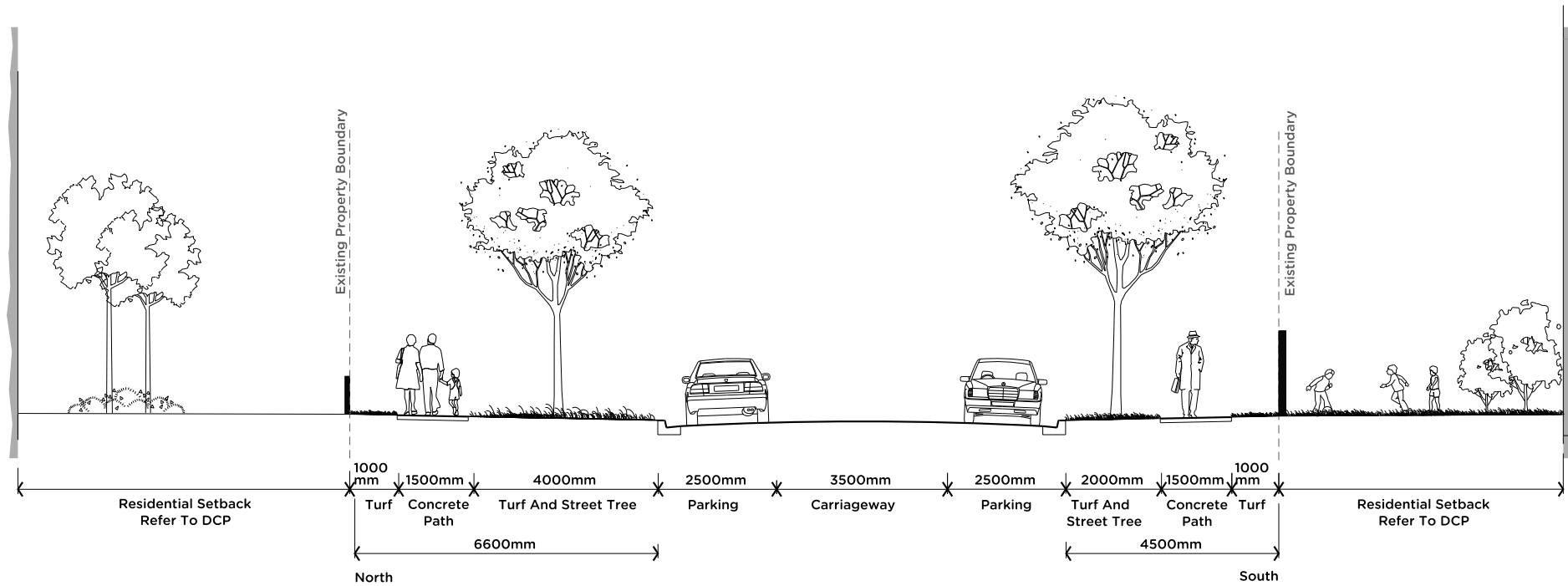

TYPICAL STREET SECTION - TERTIARY STREET

TYPICAL STREET SECTION 12 - BARBER AVENUE

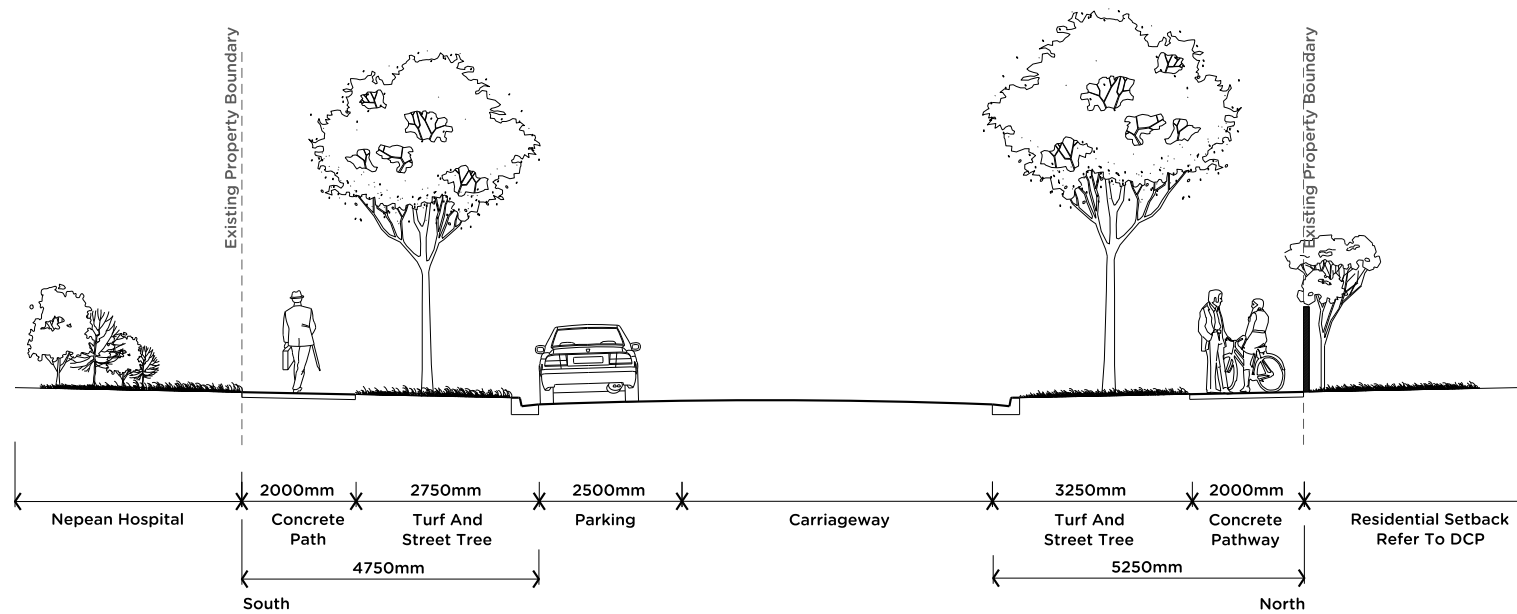

TYPICAL STREET LAYOUT PLAN - RESIDENTIAL

TYPICAL STREET LAYOUT PLAN 1 - TO BE APPLIED TO ALL RESIDENTIAL FRONTAGES

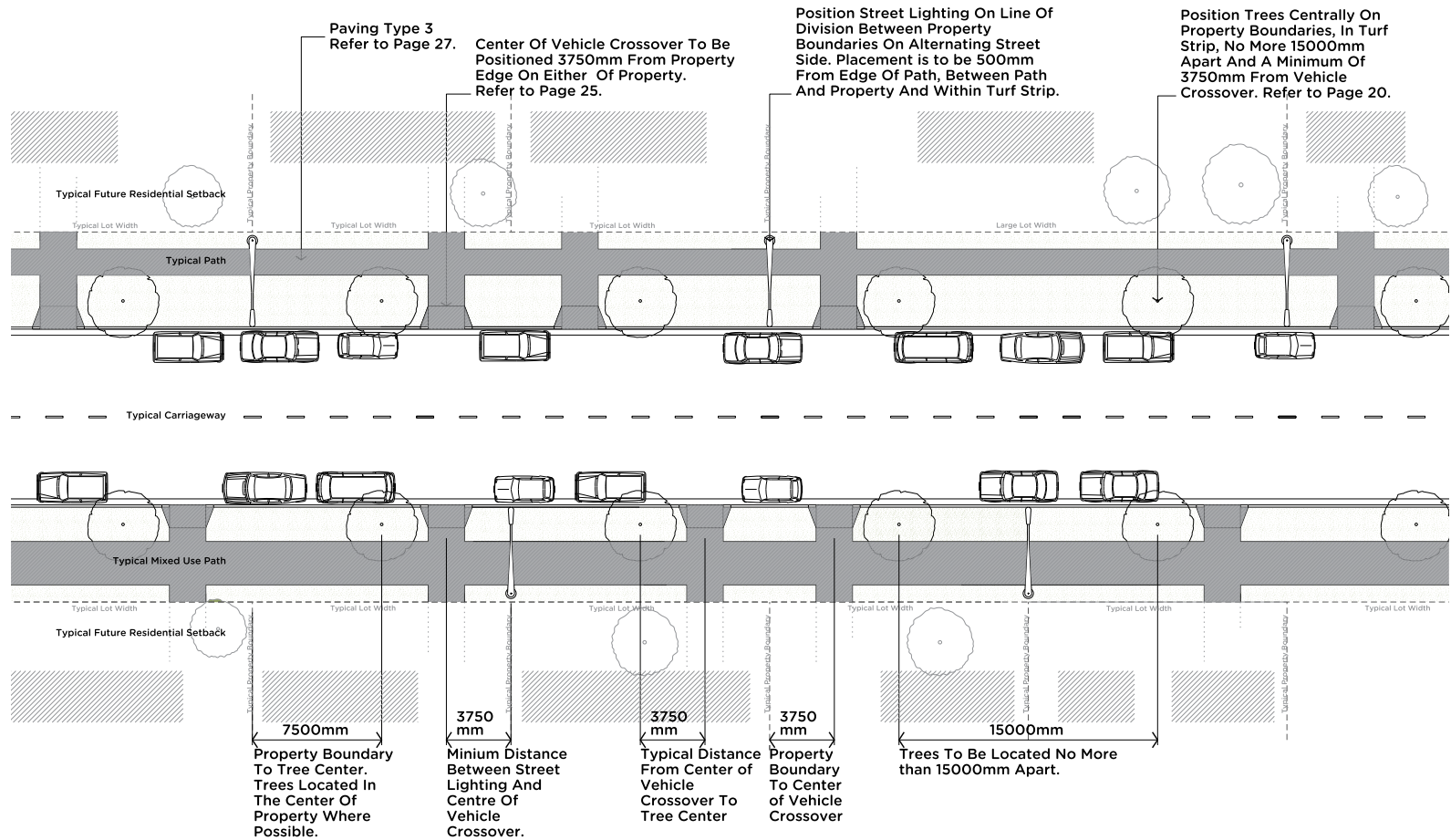

TYPICAL STREET LAYOUT PLAN - COMMERCIAL

TYPICAL STREET LAYOUT PLAN 2 - TO BE APPLIED TO ALL COMMERCIAL STREET FRONTAGES

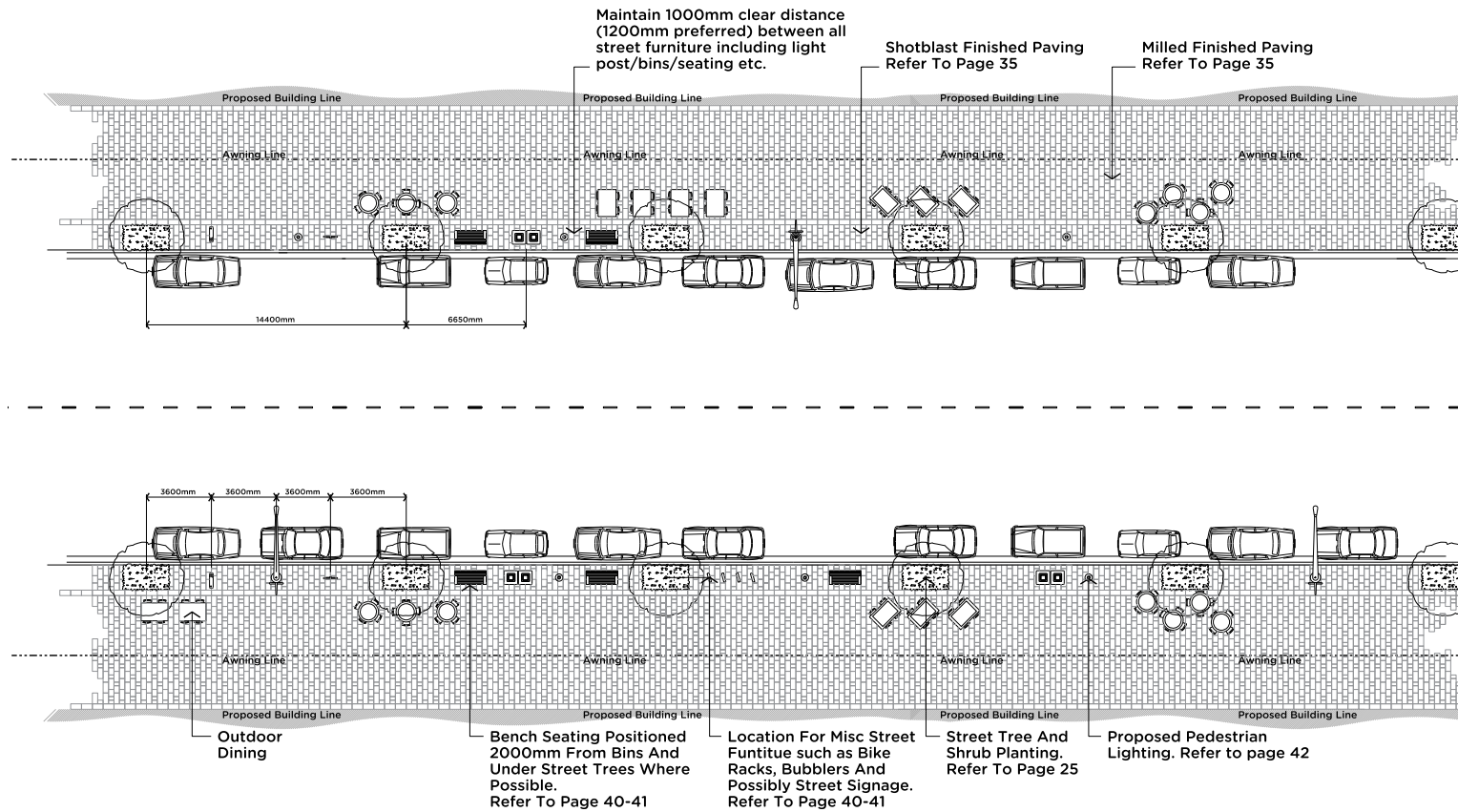

STREET TREE PLAN



STREET TREE SPECIES

STREET TREE PLANTING

Kingswood contains many existing street trees. Some are healthy specimens worthy of retention whilst others have struggled in difficult urban conditions. Many of the existing trees are Brush Box which grow well in this area however with increased development predicted council are looking to provide a more distinctive street palette.

A combination of native and exotic street trees have been selected that best respond to the existing and potential future urban conditions. The distinctive species mix will provide Kingswood with an additional overlay of colour and seasonal change.

Species have been selected for their tolerance to local climatic and urban conditions, ease of availability and appropriateness of size. The selection of some deciduous trees for east-west oriented streets will provide additional solar access to public and private domains during the winter months.

Overhead Service Lines

Most streets have overhead lines on one side. This has resulted in severe lopping of canopies for maintenance reasons. On east west streets the use of smaller tree species has been proposed as replacements to reduce the need for lopping to canopies.



Chinese Elm
Ulmus parvifolia

Height (fully grown): 12-14m
Spread (fully grown): 14-16m
Size to be planted: 400ltr
Clear stem required: 1.8m



Ornamental Pear
Pyrus calleryana 'Chanticleer'

Height (fully grown): 10-12m
Spread (fully grown): 6-8m
Size to be planted: 400ltr
Clear stem required: 1.8m



Crepe Myrtle
Lagerstroemia indica

Height (fully grown): 6-8m
Spread (fully grown): 5-7m
Size to be planted: 400ltr
Clear stem required: 1.5m



Brush Box
Lophostemon confertus

Height (fully grown): 12-15m
Spread (fully grown): 10-12m
Size to be planted: 400ltr
Clear stem required: 1.8m

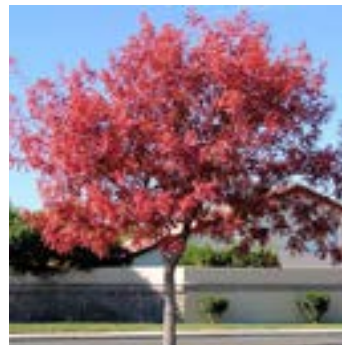

Chinese Pistachio
Pistacia chinensis

Height (fully grown): 8-10m
Spread (fully grown): 8-10m
Size to be planted: 400ltr
Clear stem required: 1.8m

Note: Only required if Council decide to build a central median.



Water Gum
Tristaniopsis laurina

Height (fully grown): 10-12m
Spread (fully grown): 8-10m
Size to be planted: 400ltr
Clear stem required: 1.8m

STREET TREE PLANTING DETAILS

Typical Detail K-01 - Street Tree in Grass Verge - Scale 1:40

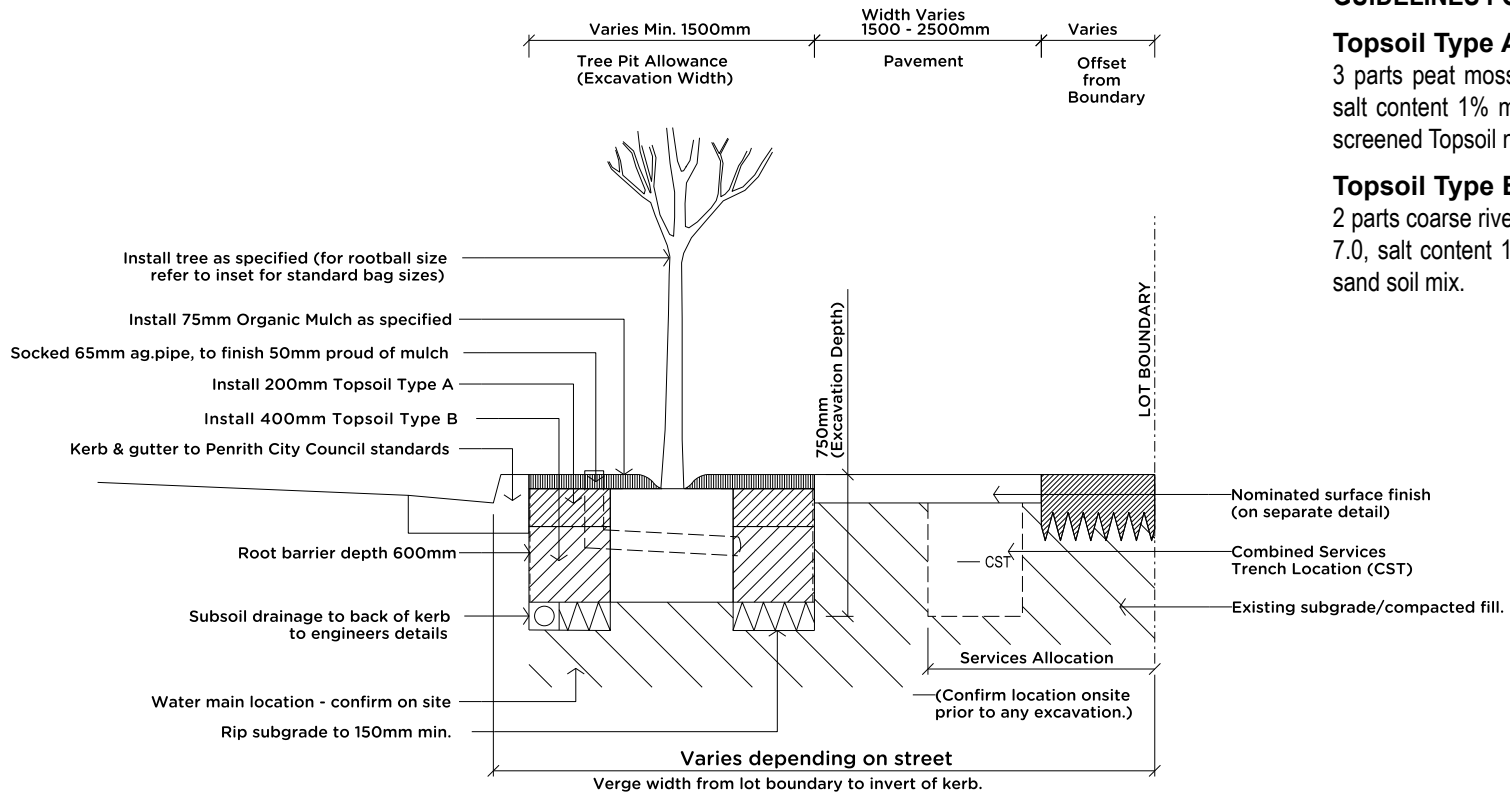

GUIDELINES FOR TOPSOIL

Topsoil Type A: 7 parts sandy loam, 3 parts peat moss, PH range 5.5 - 7.0, salt content 1% max OR Benedict 70% screened Topsoil n0.2 /30% compost

Topsoil Type B: 8 parts sandy loam, 2 parts coarse river sand, PH range 5.5 - 7.0, salt content 1% OR Benedict 80:20 sand soil mix.

STREET TREES PLANTING DETAILS

Typical Detail K-02 - Street Tree in Paving - Scale 1:40

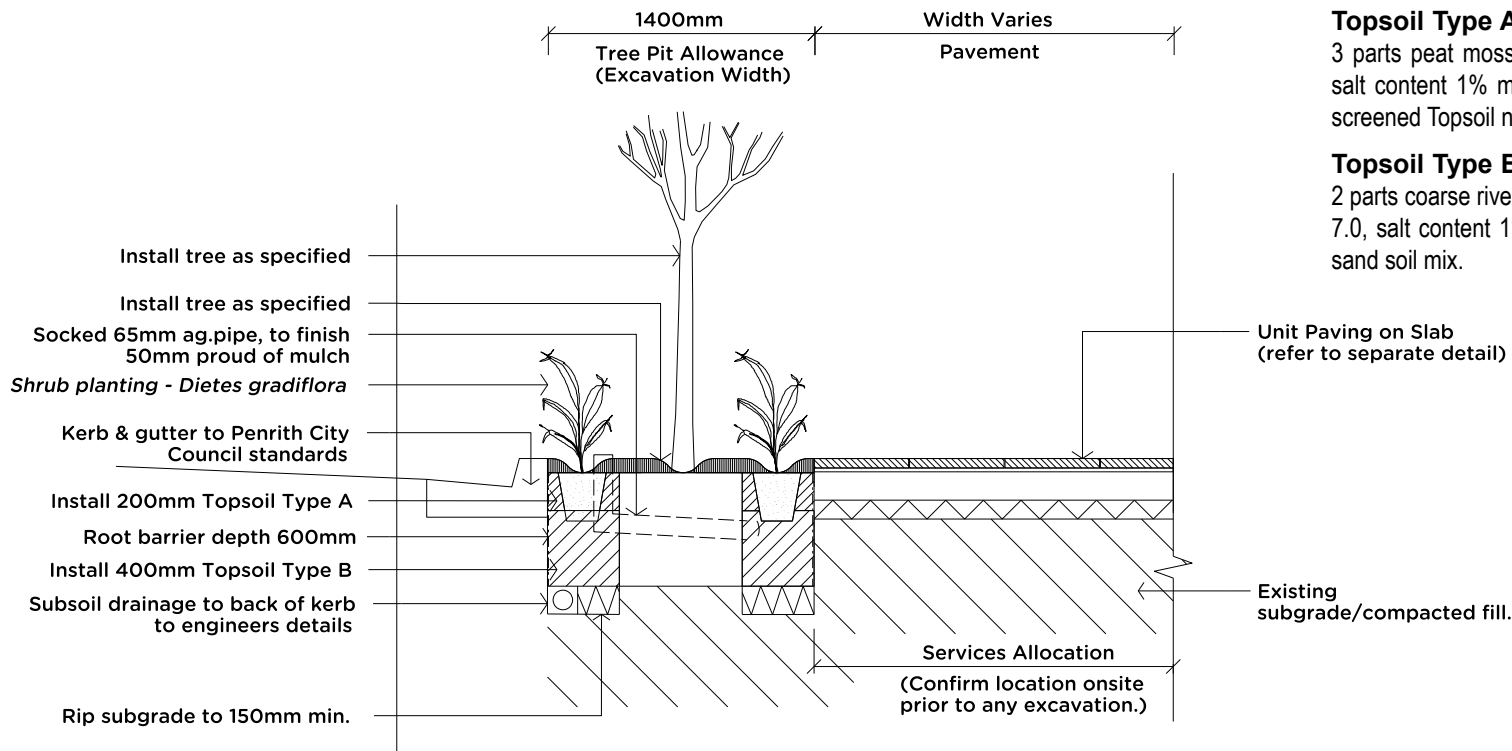

GUIDELINES FOR TOPSOIL

Topsoil Type A: 7 parts sandy loam, 3 parts peat moss, PH range 5.5 - 7.0, salt content 1% max OR Benedict 70% screened Topsoil n0.2 /30% compost

Topsoil Type B: 8 parts sandy loam, 2 parts coarse river sand, PH range 5.5 - 7.0, salt content 1% OR Benedict 80:20 sand soil mix.

TYPICAL INTERSECTION 1

Typical Intersection 1 - 90 degrees

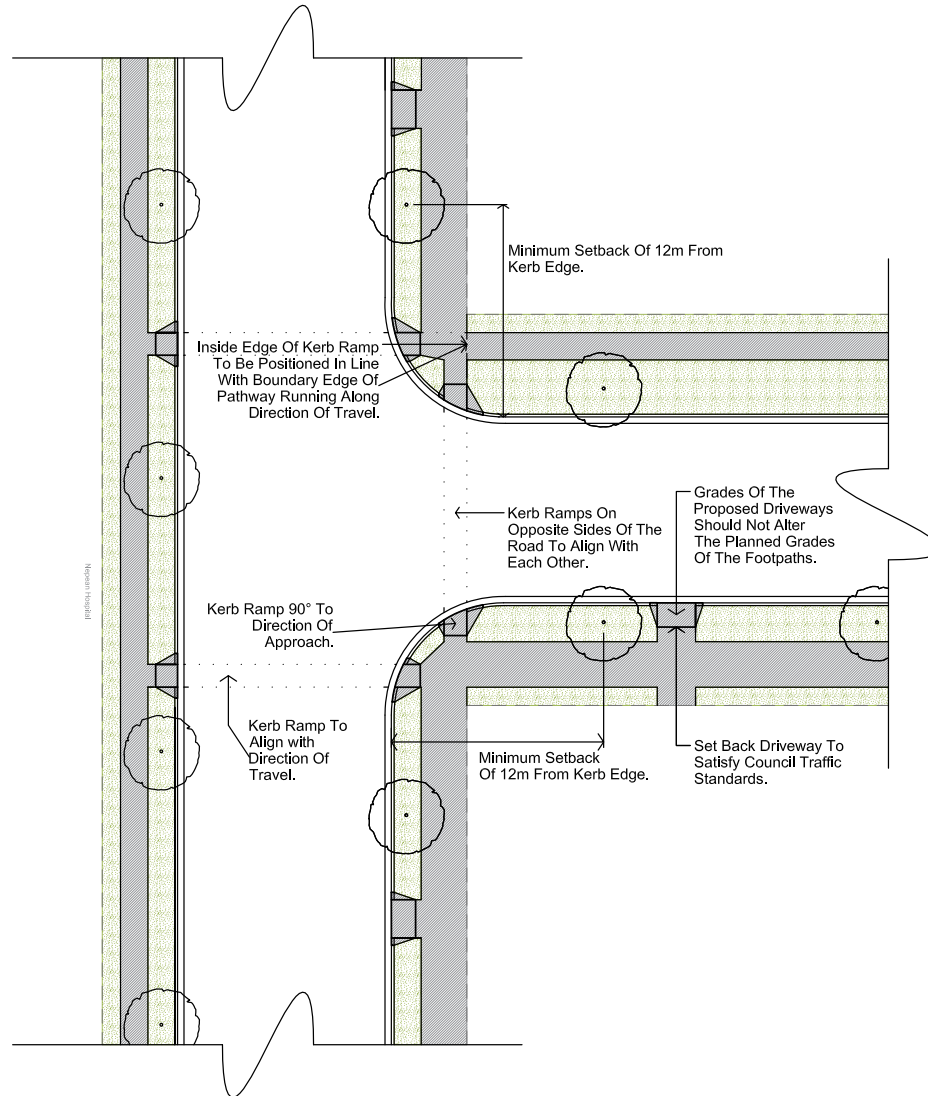

TYPICAL INTERSECTION 2

Typical Intersection 2 - Angled

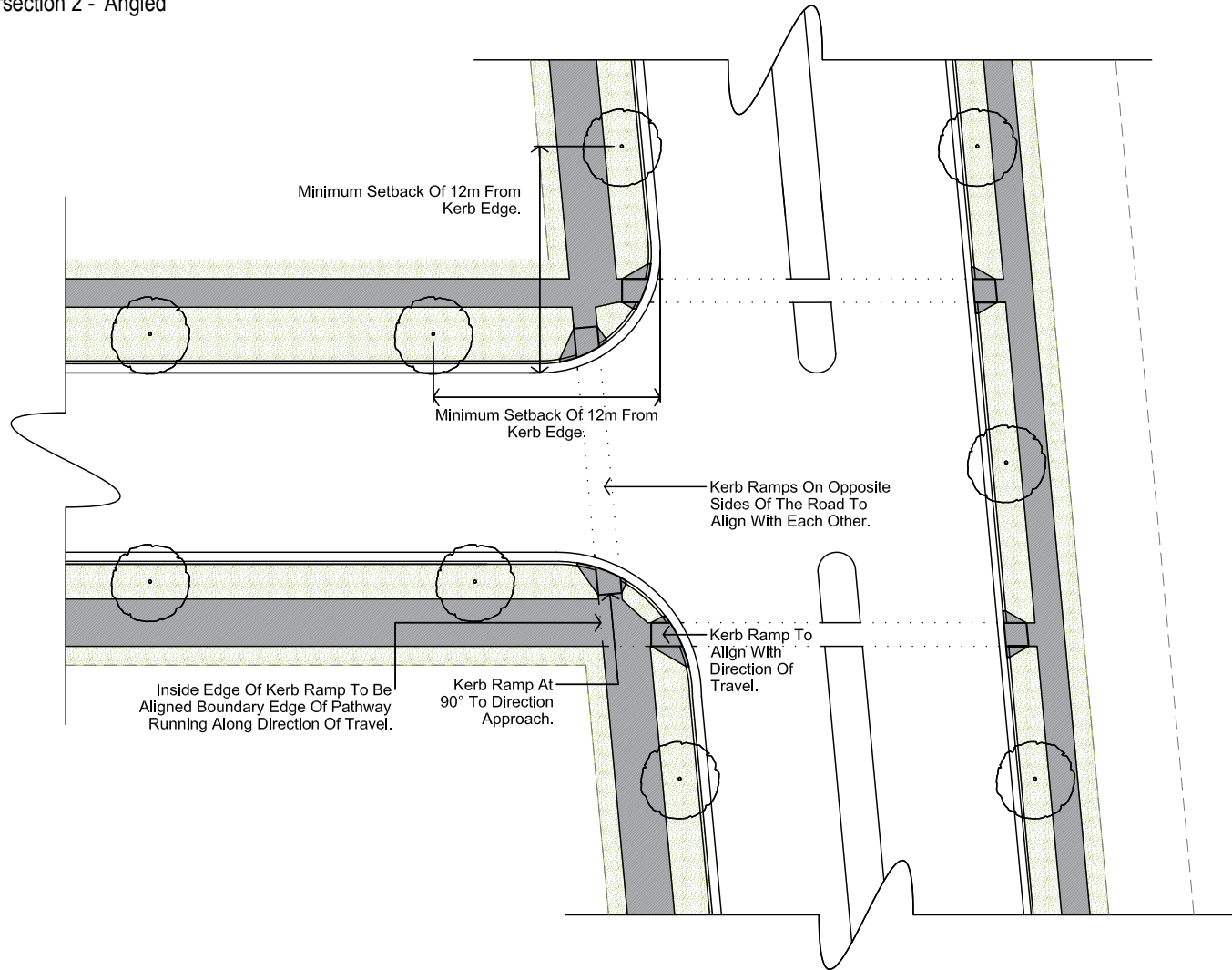

TYPICAL INTERSECTION 3

Typical Intersection 3 - Great Western Highway

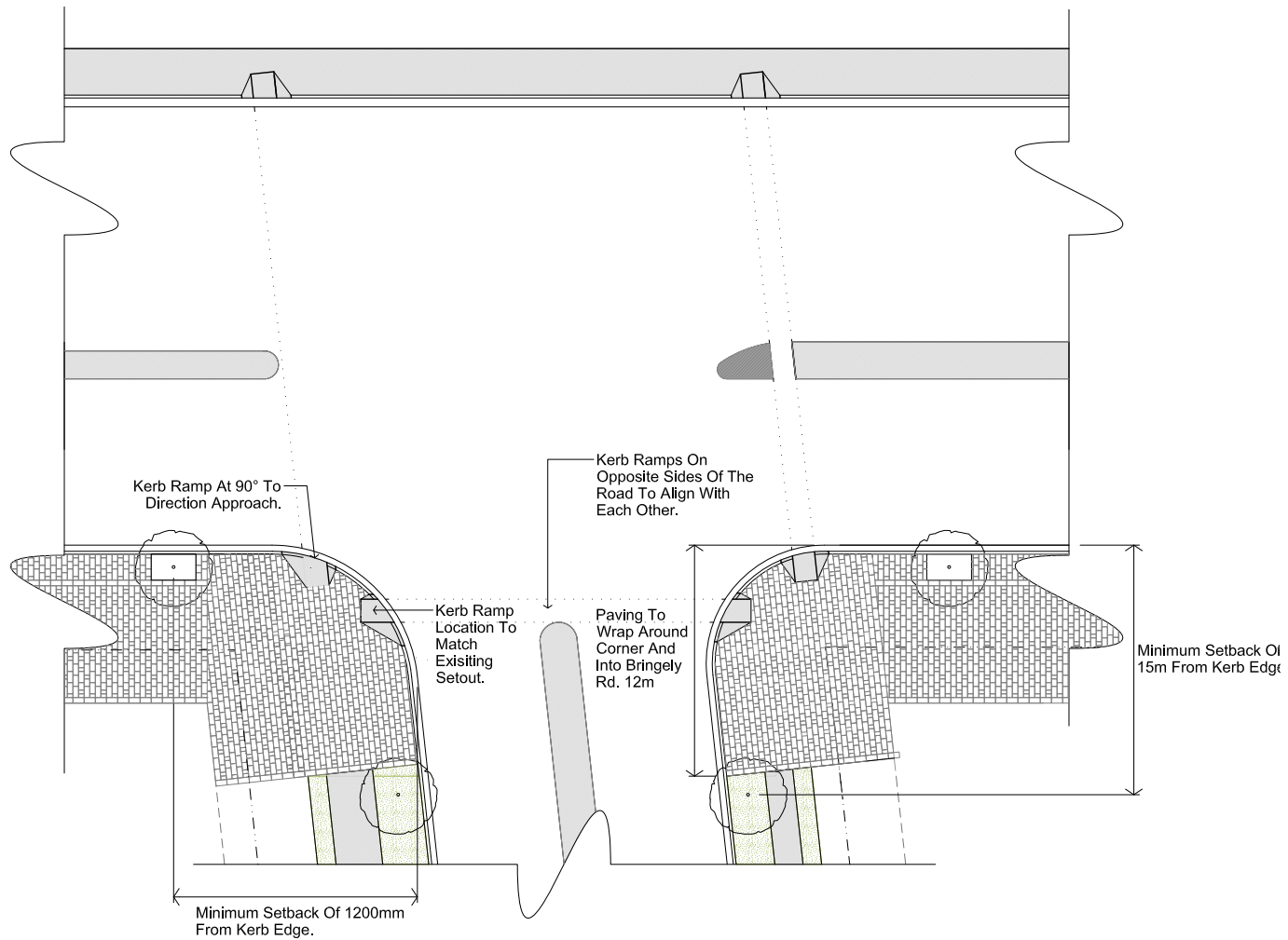

KERB RAMPS

Typical Kerb Ramp Details

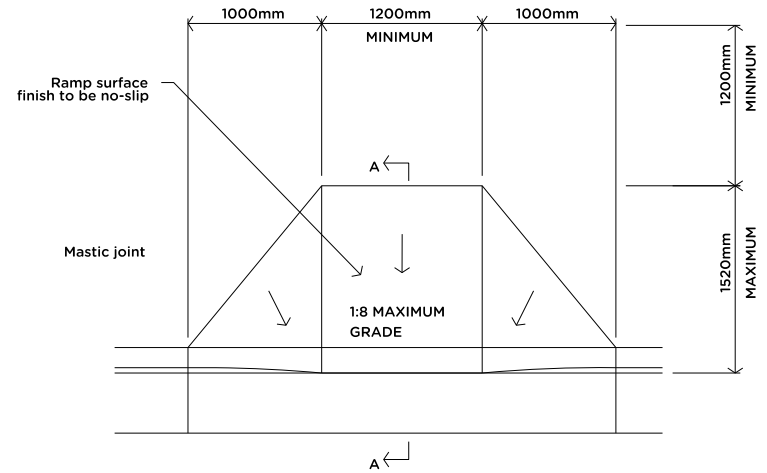
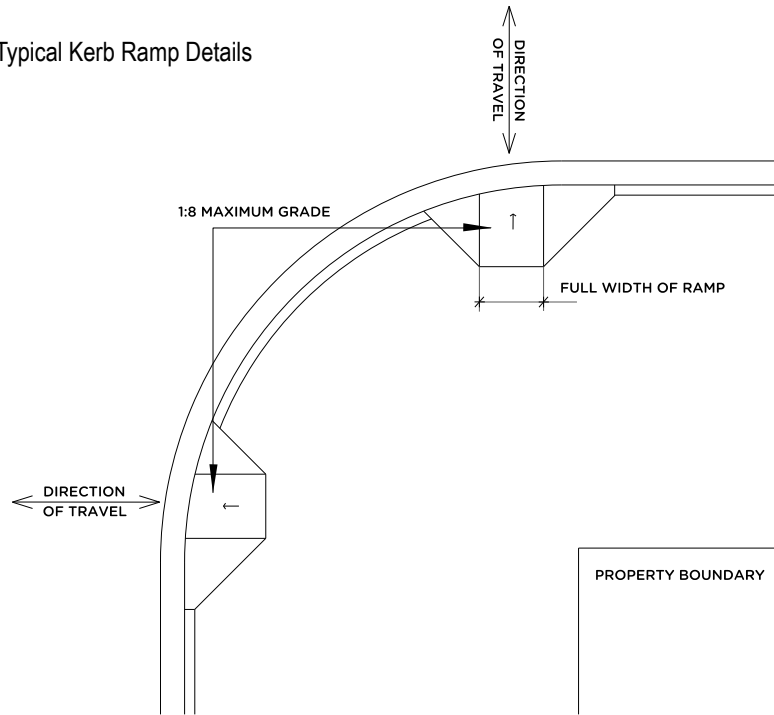

Landing space of 1500mm is required (can be reduced to 1200mm where no turn is involved in the direction of travel).

Note:

Kerb ramps should maintain the straightest line of travel as possible whilst also taking into account specific circumstances and safety requirements of the crossing point.

Council Standard Details

Please refer to Penrith City Council's standard details for:

- Kerb Ramps - Plan No: CS206b
- Kerb and Gutter - Plan No:CS206 Sheets 1 & 2

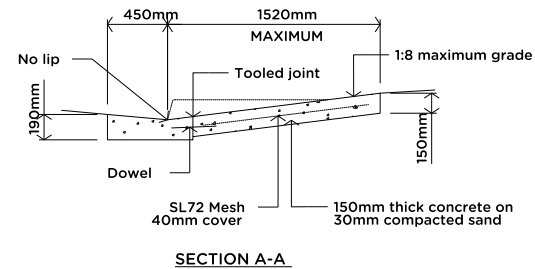

PAVING MATERIALS

PAVING PRINCIPLES

Paved and concrete footpaths are the materials for all pedestrian surfaces in Kingswood. It is critical to ensure that all footpaths are consistently accessible for the public. Council aims to have footpaths to both sides of all streets that at a minimum, meet the basic requirements of AS1428 for Access and Mobility.

This manual proposes a simple palette of paving materials for Kingswood that can be applied within its streets to ensure a consistent public domain. These materials should be applied using this manual's specific paving details on pages 28 and 29.

Paving materials have been chosen with regard to:

- Affordability
- Durability
- Ease of construction
- Ease of maintenance
- Aesthetics
- Maximising slip resistance
- Sustainability

Minimising Changes in Crossfall

Paving cross falls should be kept between 1:40 and 1:100 and should be maintained at a consistent grade along a street's length. Where shop frontages are significantly higher or lower than the public domain grades then the difference should be accommodated within the property and not compromise the public footpath.

TYPE A

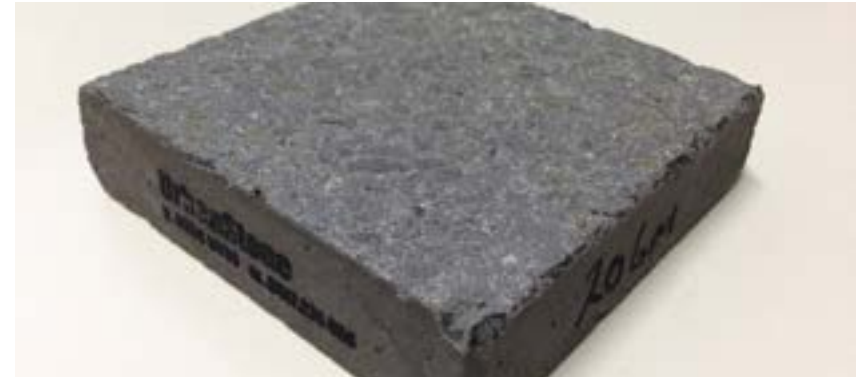

PRECAST CONCRETE UNIT PAVEMENT - MILLED

Purpose: Provides a superior finish to areas of high pedestrian movement and visibility on the Great Western Highway.

Location: Great Western Highway pedestrian circulation and outdoor dining areas

Design Considerations:

- Pavement patterns to run across pavement, perpendicular to the direction of pedestrian travel
- See paving design on page 35, 37.
- Pavement cross falls to be a minimum 1:70 and maximum 1:40.
- Lay with 5mm grouted jointing.
- Paver to meet standard (AS/NZS 4586:2004) for slip resistance
- Abutment of surfaces and changes in levels to have a smooth transition as specified in AS1428.1 to avoid the trip hazard.

Supplier: UrbanStone

Specification:

- Product: Engineering Product Range - 300 series
- Finish: Milled
- Colour: Gunmetal
- Sizes: 300x200x40mm, 300x400x40mm, 300x600x40mm

PAVING MATERIALS

TYPE B



PRECAST CONCRETE UNIT PAVEMENT - SHOT BLAST

Purpose: Provides a superior finish to areas of high pedestrian movement and visibility on the Great Western Highway.

Location: Great Western Highway pedestrian circulation and outdoor dining areas

Design Considerations:

- Pavement patterns to run across pavement, perpendicular to the direction of pedestrian travel
- See paving design on pages 35, 37.
- Pavement cross falls to be a minimum 1:70 and maximum 1:40.
- Lay with 5mm grouted jointing.
- Paver to meet standard (AS/NZS 4586:2004) for slip resistance
- Abutment of surfaces and changes in levels to have a smooth transition as specified in AS1428.1 to avoid the trip hazard.

Supplier: UrbanStone

Specification:

- Product: Engineering Product Range - 300 series
- Finish: Shotblast
- Colour: Gunmetal
- Sizes: 300x200x40mm, 300x400x40mm, 300x600x40mm

TYPE C



BROOM FINISHED CONCRETE PAVEMENT - 1.5-2.5M SHARED PATH

Purpose: Generally used in roadside footpaths and shared paths with secondary and tertiary streets.

Location: Secondary and Tertiary streets

Design Considerations:

- Provide an even textured broom finished slip resistant surface extending to the edge of placement, broom finish perpendicular to direction of travel.
- Trowelled edge longitudinally and at joints with 50mm trowelled trim on all edges of paving except where paving is to be continued in the future.
- Keyed construction joints 125mm deep with foam backing every 6m; with 16mm dowels fixed on one side of the expansion joint and plastic sleeves the other side. Jointing to engineers recommendations.
- Minimum cross fall 1:100, preferable Maximum cross fall of 1:40 in any one direction. 2% cross fall toward the road.
- Only 2.5m shared paths require line marking

Supplier: N/A

PAVING DETAILS - TYPE C

Typical Detail K-03 - Scale 1:25

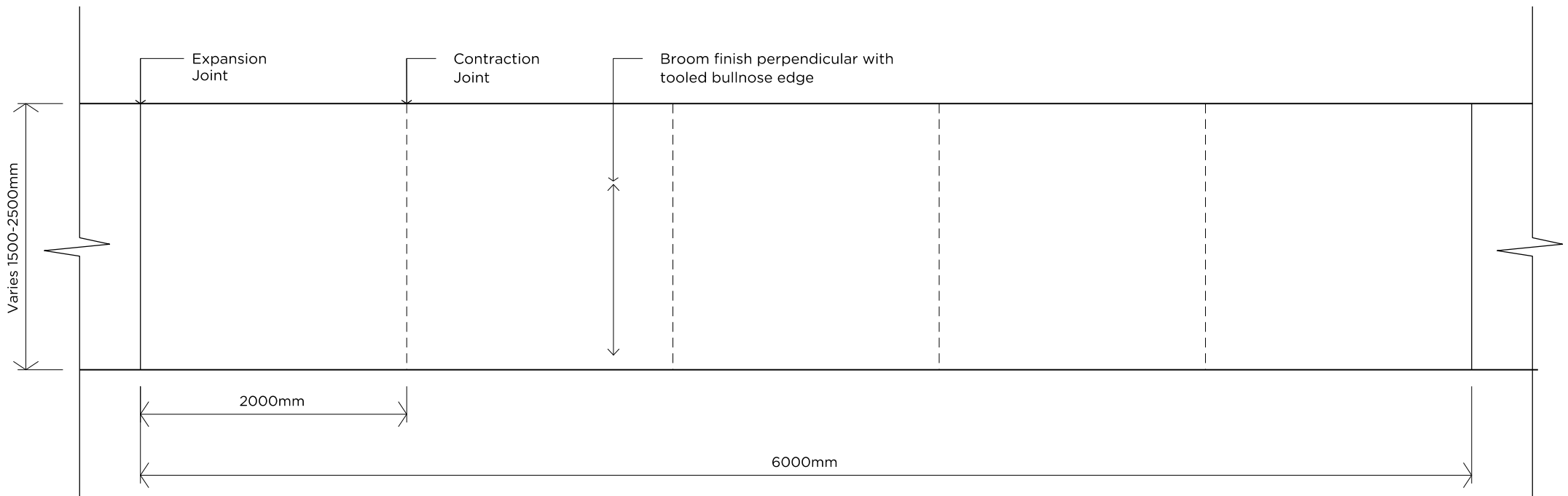

PAVING DETAILS - TYPE C CONCRETE FOOTPATH/SLAB

Typical Detail K-04 - Scale 1:20

NOTES: Joint Sealant: 10mm wide x 15mm deep expandite "Thioflex 600" joint sealant recessed with polythene tape bond breaker or approved equivalent, place tape after sides of recess have been primed for sealant

Joint Filler: 10mm thick Expandite "Flexcell" compressible filler board, or approved equivalent.

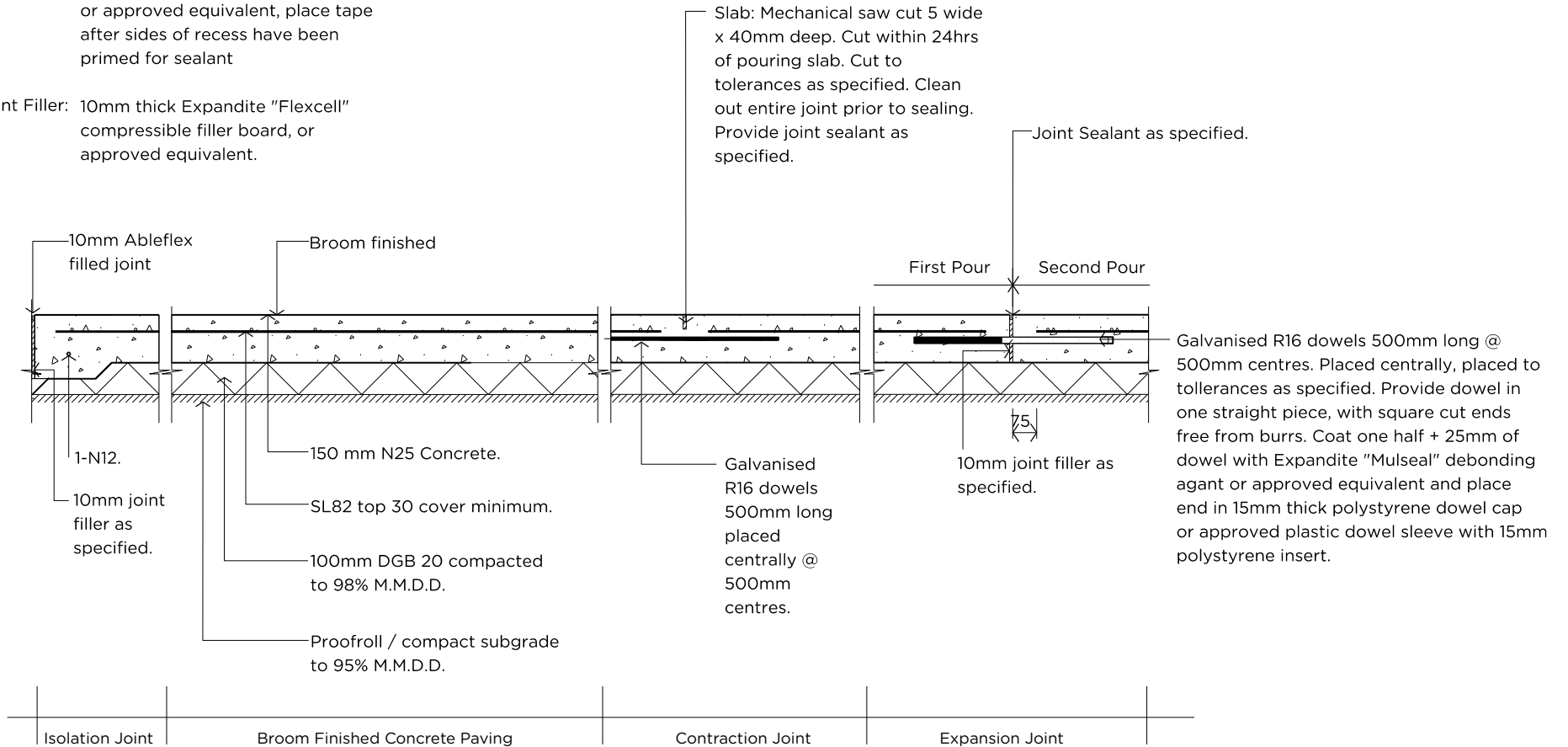

PAVING DETAILS - UNIT PAVING (FOR INCREASED SETBACK)

Typical plan - Scale N/A

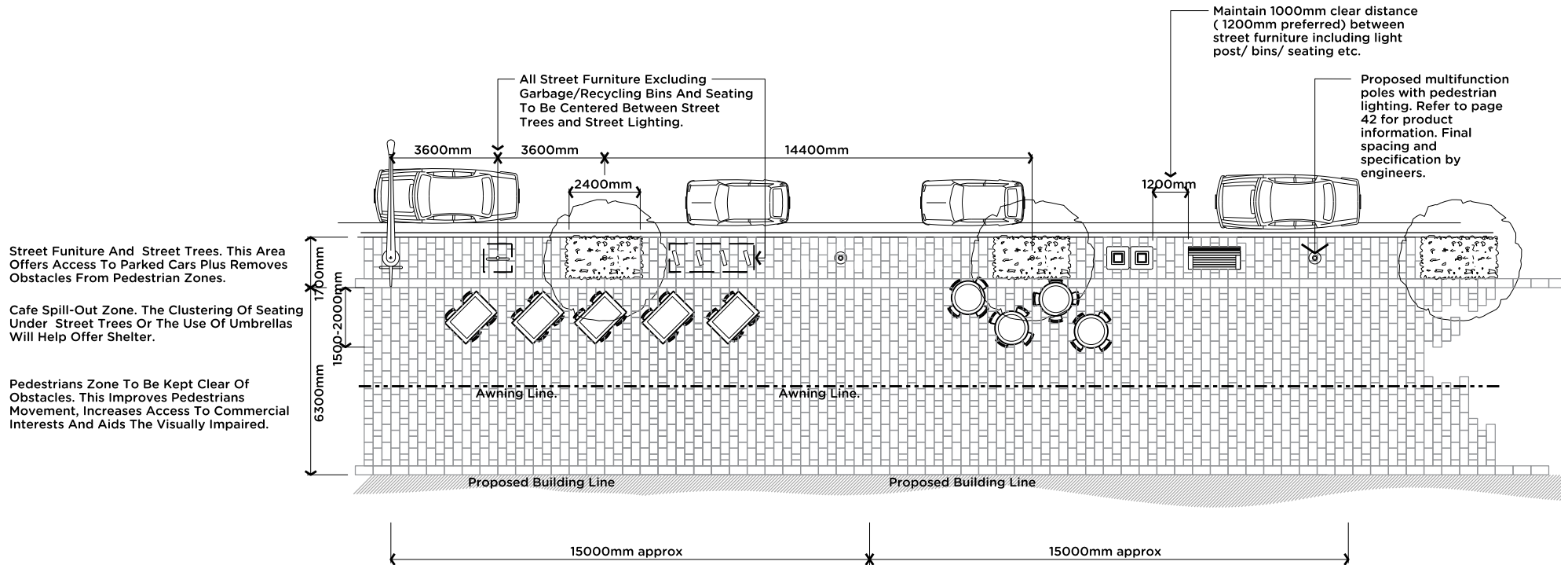

PAVING DETAILS - UNIT PAVING (FOR INCREASED SETBACK)

Typical Detail K-05 - Enlarged Area - Scale N/A

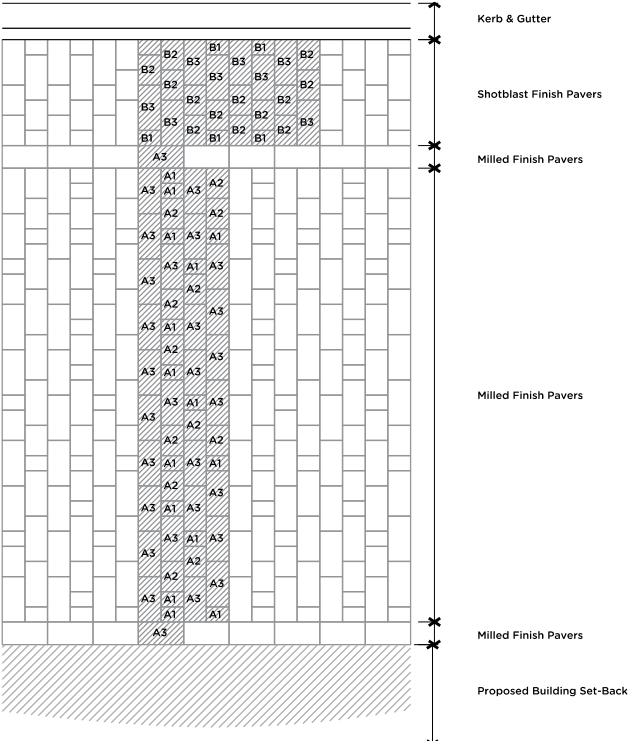

- Paving type - A1 = 300 x 200 x 40mm
- Paving type - A2 = 300 x 400 x 40mm
- Paving type - A3 = 300 x 600 x 40mm
- Paving type - B1 = 300 x 200 x 40mm
- Paving type - B2 = 300 x 400 x 40mm
- Paving type - B3 = 300 x 600 x 40mm

Typical Detail K-06 - Scale 1:20

NOTES:
 Joints All contraction, expansion joints and sealants for the concrete slab must be carried through the the surface of the paving. Please refer to page 33 for concrete slab and joints detail.

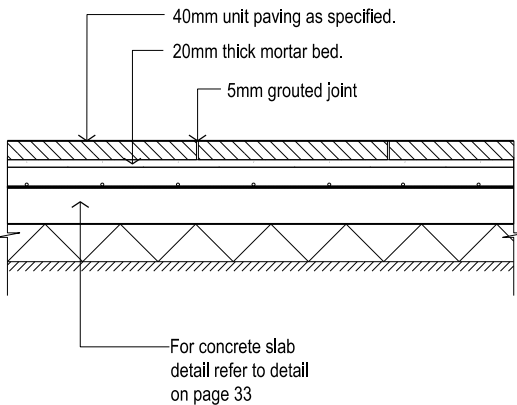

PAVING DETAILS - UNIT PAVING (FOR CURRENT SETBACK)

Typical plan - Scale N/A

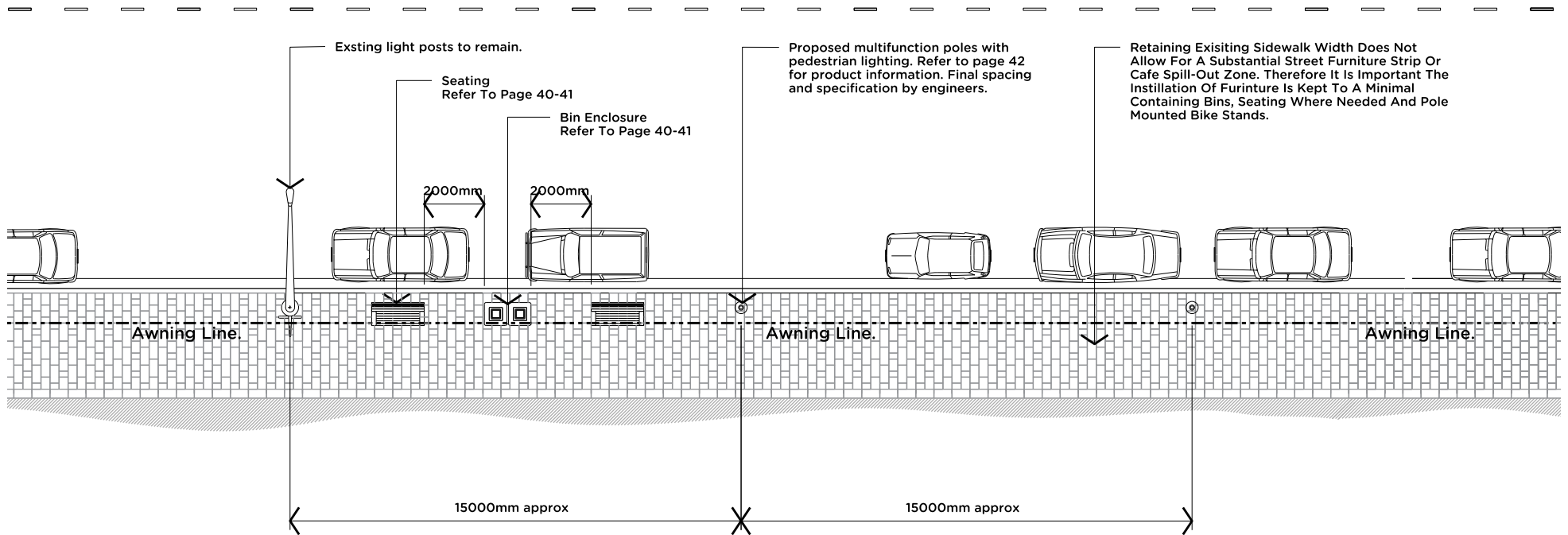

PAVING DETAILS - UNIT PAVING (FOR CURRENT SETBACK)

Typical Detail K-07 - Enlarged Area - Scale N/A

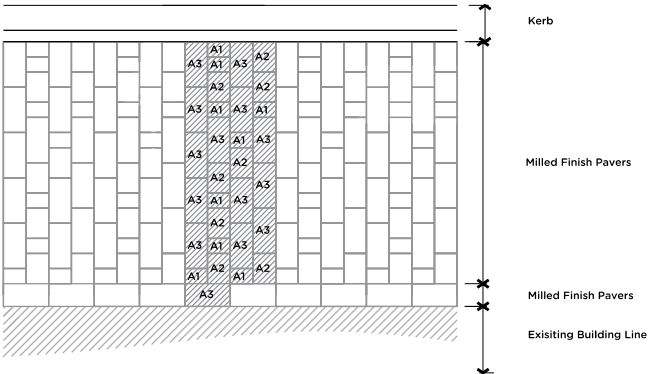

- Paving type - A1 = 300 x 200 x 40mm
- Paving type - A2 = 300 x 400 x 40mm
- Paving type - A3 = 300 x 600 x 40mm

Typical Detail K-08 - Scale 1:20

NOTES:
 Joints All contraction, expansion joints and sealants for the concrete slab must be carried through the the surface of the paving. Please refer to page 33 for concrete slab and joints detail.

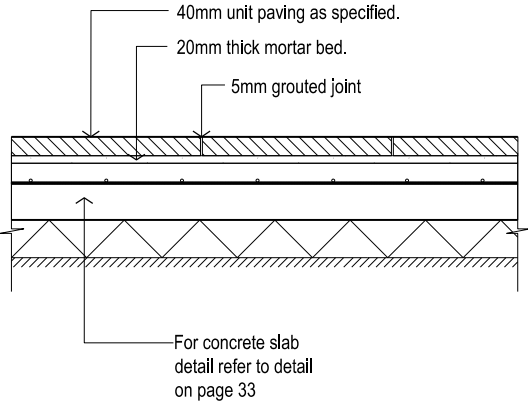

TACTILE INDICATORS

TACTILE INDICATORS PRINCIPLES

Tactile indicators are only required at intersections and crossings with The Great Western Highway unless otherwise indicated by Council.

The indication of tactile indicators within this manual is a guide and installation must be in accordance with AS1428 and Council standards.

CONDITIONS OF SELECTION

If alternatives are permitted a certification document should be required from manufacturer stating that the TGSIs have been tested and found compliant by a NATA certified laboratory for luminance contrast requirements of AS1428 and slip resistance requirements.

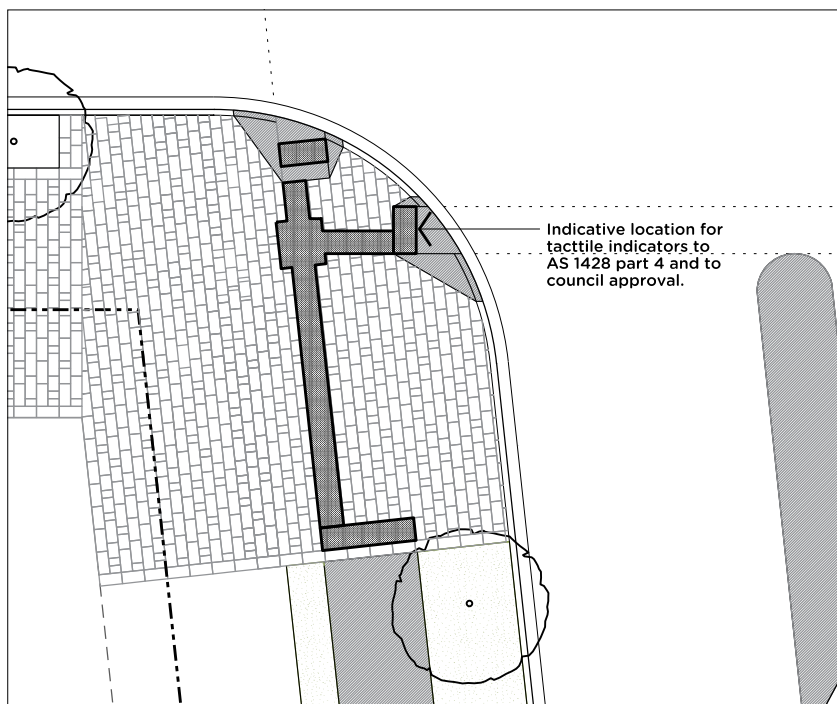

REASONS BEHIND CONDITIONS OF SELECTION

Luminance contrast requirements vary with the type of TGSIs selected. For example, Integrated TGSIs require minimum of 30% luminance contrast whereas discrete TGSIs require minimum 45% luminance contrast and discrete with 2 colours require a minimum of 60% luminance contrast.



PRECAST CONCRETE TACTILE PAVERS

Purpose: Provides a superior finish to areas of high pedestrian movement and visibility on the Great Western Highway.

Location: Great Western Highway pedestrian crossings

Supplier: UrbanStone

Specification:

- Product: Speciality Series Tactile Type B and C
- Colour: Granite Cream
- Size: 300 x 300 x 40mm

SERVICES COVERS AND DRAINAGE GRATES

SERVICE COVER PRINCIPLES

Existing and new service covers can cause a number of difficulties when implementing and maintaining a unit paved pedestrian zone. If not properly considered they can easily degrade the appearance of an otherwise well implemented design.

Some key principles to observe are:

- Liaise with service authorities to determine future service requirements.
- Where possible consolidate services by providing generous combined service trenches/conduits.
- Use infill pit covers and where possible ensure that the infill paving material matches the adjacent surface.
- Ensure that pit covers are aligned with the direction of the paving to minimise cutting and provide a neat finish.
- Ensure pit covers are flush with adjacent surfaces to avoid tripping hazard.
- Use service cover frames that allow for paving to finish flush with the frames with no visible concrete edge.
- Where drainage cannot be directed to the existing kerb and gutter ensure that drainage grilles
- 'Grates if used in the accessible path of travel should be oriented so that the long dimension is transverse to the dominant direction of travel. Follow AS1428 for further details.'



Infill service cover with unit paving



Hydrant cover. Square to paving direction and paving flush to frame



Stormwater cover installed square to paving

STREET FURNITURE

FURNITURE PRINCIPLES

Street furniture is an important element in the public domain. A good selection that is located correctly can contribute to a well organised street, providing high levels of aesthetic and functional amenity.

This range of new street furniture provides an opportunity to replace ageing furniture around Kingswood with co-ordinated, more attractive pieces. Over time these will provide a level of consistency within the public domain, giving Kingswood a distinct character profile.

Street furniture proposed in this manual has been chosen with regard to:

- Affordability
- Durability
- Consistency of appearance and materials
- Ease of maintenance
- Availability
- Aesthetics
- Sustainability

Locate all street furniture at a minimum distance of 2000mm from the building shore line.



SEAT

Purpose: To provide a comfortable resting place for pedestrians. Provides back support and arms to assist less able bodied users.

Location: To be positioned close to community facilities such as shops, bus stops and parks or where gradients necessitate a resting point to the less able bodied. Positioned not to obstruct pedestrian movement or safety.

Supplier: Urban Art Projects

Product: Port Seat

Code: PRT01

Dimensions: L1750 x D635 x H925 mm

Finish: Galvanised steel + Spotted Gum Slats

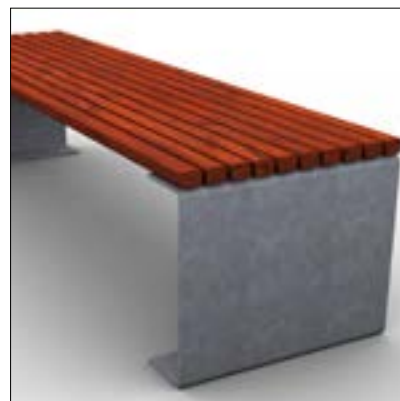

BENCH

Purpose: To provide a comfortable resting place for pedestrians. Allows for seating in two directions if required.

Location: To be positioned close to the line of pedestrian travel and near to services/retail that generate waste (takeaways etc). Ensure position does not obstruct pedestrian or vehicular movement or safety.

Supplier: Urban Art Projects

Product: Port Bench

Code: PRT02

Dimensions: L1750 x D510 x H450 mm

Finish: Galvanised steel + Spotted Gum Slats



BIKE RACK (FREE STANDING)

Purpose: To encourage the use of bicycles as a form of local transportation. Allows for safe locking of bicycles to guard against theft.

Location: To be positioned close to community facilities, services and shops. To be placed in a location that does not obscure pedestrian or vehicle movement or cause a hazard.

Supplier: Urban Art Projects

Product: Port Bike Rack

Code: PRK09

Dimensions: 500 x 120 x 800mm

Finish: Galvanised

STREET FURNITURE



BIKE RACK (POLE MOUNTED)

Purpose: To encourage the use of bicycles as a form of local transportation. Allows for safe locking of bicycles to guard against theft.

Location: To be retrofitted to signage posts such as parking signs.

Supplier: Urban Art Projects

Product: Available on request to match style and finish of Port Bike Rack.

Code: N/A

Dimensions: TBC

Finish: Galvanised



BOLLARD (FIXED OR REMOVABLE)

Purpose: To block vehicle movements for pedestrian safety or security reasons.

Location: To be positioned behind or in line with adjacent kerb lines or along the boundary of open spaces. Spaced to prohibit vehicles passing between.

Supplier: Urban Art Projects

Product: Channel Bollard

Code: CHL04

Dimensions: L 200 x D 200 x H 910

Finish: Galvanised



BIN ENCLOSURE

Purpose: To provide a robust and attractive enclosure for garbage and recycling wheel bins.

Location: To be positioned close to the line of pedestrian travel and near to services/retail that generate waste (takeaways etc). Ensure position does not obstruct pedestrian or vehicular movement of safety.

Supplier: Botton + Gardiner

Product: Double Bin Housing with aluminium panels

Code: Housing - BH2.120.AL.PC.PL

Vaulted Cover - BHH.PC.PL

Dimensions: H1195 x L1340 x W655mm

Finish: Aluminium panels



BUBBLER

Purpose: To provide drinking fountain, bottle refill, tap and dog dish.

Location: To be positioned close to pedestrian circulation/paths. Final locations to be determined by Council

Supplier: Street & Garden Furniture Co.

Product: Delta Water Station

Code: N/A

Dimensions: H890 x L840 x W200mm

Finish: Stainless steel and powder coated steel

LIGHTING PRINCIPLES

LIGHTING PRINCIPLES

Street lighting is an important part of pedestrian and traffic safety. Kingswood currently uses a combination of standard light posts as well as street lights fitted to electricity and telecommunications pylons (primarily in secondary and tertiary streets).

Council aim to achieve a more consistent approach to secondary and tertiary streets by implementing independent and regularly spaced light poles while focussing more specialised treatments to the Great Western Highway frontage (see right).

Primary Streets (Great Western Highway)

- Utilise existing light poles.
- No lighting to be attached to shop awnings.
- Additional pedestrian lighting to utilise the Multipole system and provide lighting standards to AS/NZS 1158.3.1 **Category P2**
- Street trees to be positioned a suitable distance from light posts to reduce shadowing from foliage.
- Final lighting set-out and luminaire levels to be determined by a qualified engineer to council/RMS standards.

Secondary and Tertiary Streets

- Light poles to be installed in place of pylon mounted fittings where possible.
- Street trees to be positioned a suitable distance from light posts to reduce shadowing from foliage.
- Light poles to be positioned within the verge between the footpath and the property boundary
- Final lighting set-out and luminaire levels to be determined by a qualified engineer to council/RMS standards.

GREAT WESTERN HIGHWAY PEDESTRIAN LIGHTING

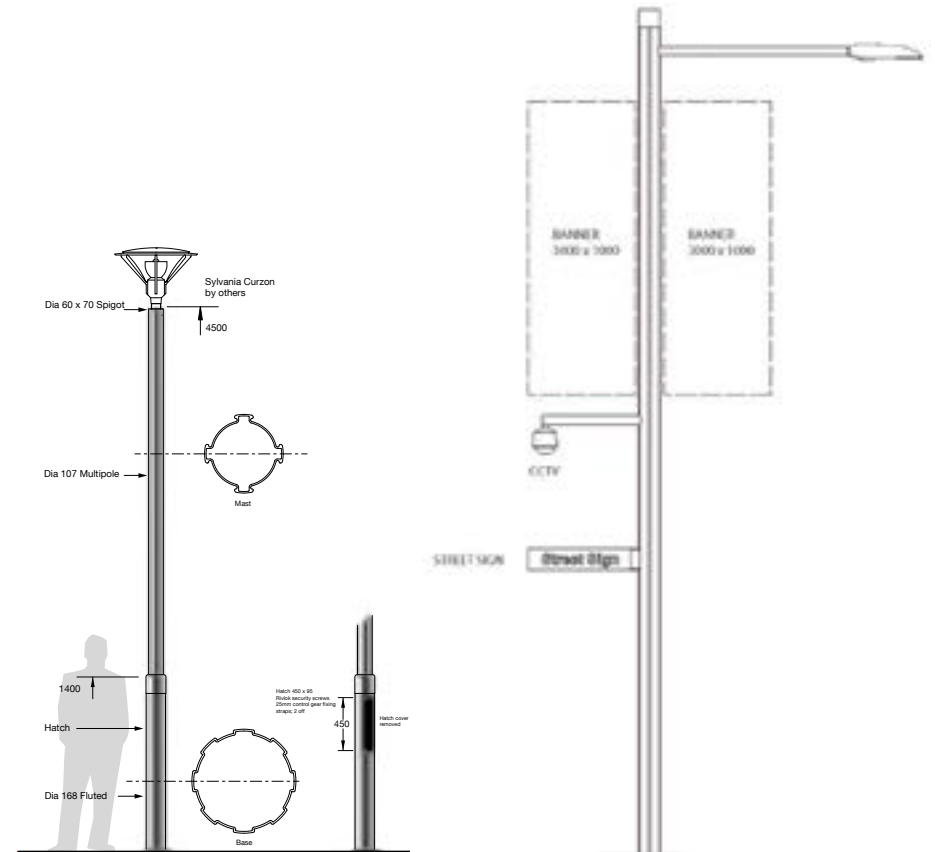

STAND ALONE PEDESTRIAN STREET LIGHTING - OPTION 1

Supplier: Multipole

Product: 168 Tuggeranong Series

Dimensions: 4500mm Height

Finish: Clear satin anodize 20 Um

STAND ALONE PEDESTRIAN STREET LIGHTING - OPTION 2

Supplier: Multipole

Product: 161 Series

Dimensions: Up to 7000mm Height

Finish: 20 Micron natural satin anodize

MAINTENANCE GUIDELINES

STREETScape MAINTENANCE

Street Sweeping to Gutters

Penrith City Council apply a general street cleaning regime under their “service specification” which allows for sweeping of roadway gutters every 4 weeks. This regime applies to all streets across the LGA except all “major” roads under the ownership of the RMS (including the Great Western Highway and the Northern Road).

Footpaths Cleaning

Penrith City Council’s “shopping centre” crew clean the footpaths in front of the 2 designated shopping areas (the “Kingswood Shops” that front the GWH & “Bringelly Shops” on both sides of Bringelly Road).

This crew also defer the need for any specific high pressure cleaning of certain areas of the footpaths in these locations (usually under street litter bins) to the “high pressure cleaning” crew that would attend to reported incidents as soon as possible.

Its expected that Council will carry out some amount of high pressure cleaning of footpath areas in front of the shops on a 3-monthly/quarterly basis. The remaining footpath areas within the defined Kingswood PDTM area would be cleaned on a “as requested/required” basis.

Litter collection by Council’s “little litter” crew is undertaken fortnightly around the edge of the Hospital precinct..

Graffiti Removal

Council’s “graffiti” crew remove all reported graffiti from Council assets within 3 business days, while a contractor undertakes removal from private property subject to the graffiti being accessible from the public space. All offensive graffiti is removed within 24 hours.





PROJECT CREDITS

CLIENT:
PENRITH CITY COUNCIL

Contact: Terry Agar - City Centres Coordinator

CONSULTANT TEAM:

Leonard Lynch - Managing Director

Nick Bucktin - Project Manager

Martin O'Dea - Technical Guidance

Kevin Simpson - Production

Paul Bu - Production

of

CLOUSTON Associates

Landscape Architects • Urban Designers • Landscape Planners

Level 2, 17 Bridge Street • Sydney NSW 2000

PO Box R1388 • Royal Exchange NSW 1225 • Australia

Telephone +61 2 8272 4999 • Facsimile +61 2 8272 4998

Contact: Leonard Lynch

Email • sydney@clouston.com.au

Web • www.clouston.com.au

Farah Madon, Vista ACCESS Architects Pty. Ltd.

Disability Consultant

PO Box 353, Kingswood NSW 2747 • Australia

Telephone +61 412 051 876

Contact: Farah Madon

Web - www.accessarchitects.com.au

Email - admin@accessarchitects.com.au